

TechData

POWERED SYSTEM OPERATIONS

AUTOMATIC BRAKE FOR POWERED CARRIAGES

Spacesaver's Automatic Brake for powered carriages provides patent pending state-of-the-art technology to help prevent carriage drift as a result of excessive floor deflection.

BENEFITS

1. **Code Compliance:** The Automatic Brake for powered carriages can aid in compliance with building code issues regarding floor loading capacity by greatly increasing the allowable floor deflection for Spacesaver powered high-density mobile storage systems.
2. **Cost Savings:** May help minimize the need for structural retrofits requiring floor reinforcing to reduce deflection under high-density mobile storage systems. A Spacesaver powered high-density mobile storage system equipped with Automatic Brakes may be price-competitive vs. costly structural retrofits.
3. **Safety:** Powered carriages equipped with the Automatic Brake will stay parked where they belong even if moderate floor deflection occurs. Carriages will not drift to close an occupied aisle. Aisle width remains constant.
4. **Security:** Provides additional braking to all drive wheels even if the power is turned off to the system or during a power outage. Carriages cannot be manually pushed to access media in a closed aisle. Especially beneficial when combined with the TouchPad Aisle Access and TouchPad System Access security options. Aids the 1996 Health Insurance Portability and Accountability Act (HIPAA) compliance by providing an additional means of locking sensitive documents. HIPAA, among other things, requires health information to be kept private.

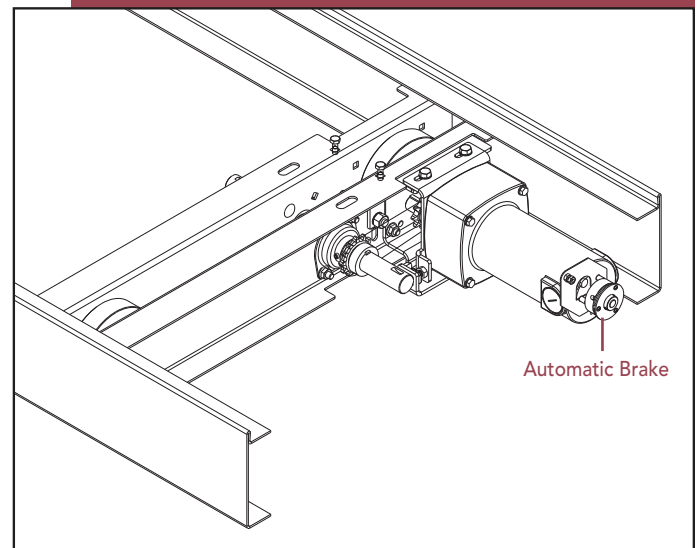

DESIGN AND CAPABILITIES

Patent pending and UL Listed, the Spacesaver Automatic Brake is factory mounted on the back of the carriage motor and is designed to be completely maintenance free. It is engineered to be normally locked providing security and safety even during a power interruption. Brake status can be monitored via PowerLink and is activated by a 12VDC power supply regulated by the solid-state microprocessor controlled carriage logic assembly.

APPLICATION

The Automatic Brake is compatible with all Spacesaver powered synchro and line shaft carriages and all three guidance types (roller guide bearing, center flange, and dual flange).

Note that a floor load analysis must be performed by a licensed structural engineer registered to practice in the location of the high-density mobile storage installation.

TechData

AUTOMATIC BRAKE FOR POWERED CARRIAGES

TECH SPEC

Automatic Brake for Powered Carriages:

All carriages shall be equipped with a minimum of one 12VDC Automatic Brake regulated by the solid-state microprocessor controlled carriage logic assembly. Carriage motors equipped with an Automatic Brake shall exhibit a holding force (torque) sufficient to prevent carriage drift on floor systems deflecting up to L/360. Brake status shall have the capability to be monitored on systems equipped with PowerLink remote system monitoring. Brake shall be UL listed in both the U.S. and Canada.

Specifications subject to change.