

# Installation Guide

# Table of Contents

Overview	2
Definitions	3
Tools and Materials	4
Installing Lockers	5
1.0 Base Construction	5
2.0 Unloading	5
3.0 Connecting Lockers	6
4.0 Securing Lockers	6
5.0 Filler Panels	6
6.0 End Panels	7
7.0 Crown Moulding and Valance	7
8.0 Slope Top	8
9.0 Number Discs	9
10.0 Hinge Adjustment	9
11.0 Base Trim	9
Care and Cleaning	10

# Overview

The purpose of this guide is to provide basic instruction on methods, techniques and materials needed to successfully install your new lockers.

It is not intended to be all inclusive and written with the expectation that the installer has the necessary knowledge to operate the tools needed for the installation and has woodworking experience. It is not possible to describe all situations and their solutions in this format.

## **Basic installation process :**

- Room dimensions are verified and plan created showing locations and dimensions of all room elements. This is necessary to determine that there is sufficient space for the lockers and that all parties understand the expected outcome.
- Base is built, set in place, leveled and secured.
- Lockers are unloaded, hardware kit located in locker with yellow tape.
- Lockers are set in place, level and plumb, secured to base, wall and bolted to each other.
- Trim is installed: Crown, finished base trim or valance.
- Doors checked for function, swing, lock operation and adjusted as necessary.
- Number discs and name plates, as appropriate to the order are put on.
- Lockers are cleaned and punch list created and corrected.
- Turn over to the customer.

# Definitions

## Base

Installed under the lockers to allow for proper door function and create a toe kick space. Recess is 3" from front of lockers. Sides are recessed 2"-3", plus the SEP or DEP. When install is complete you should not see any raw material when looking down at the base. Defined in quotes as (L/F/R= Left, Front, Right) for what finished area is needed, if any. If a finished area is not needed the base is defined as (raw). The base trim can be sent loose.

## Connector Bolt

Two part bolt, Male and Female. Used to secure lockers together. All lockers have pre-drilled holes for 3-4 of these connector bolts. Male goes on one side, Female the other and screwed together. This draws the units tight to each other and combined with other methods prevents tip over .

## Crown

Or Crown Moulding. Decorative wood shape used to finish off the top of the lockers. Also used as a transition between wall and ceiling surfaces. Made from solid wood, MDF, veneer wrapped MDF or extruded PVC. Legacy has a standard crown profile and height. For custom work, crown can be made as a multiple piece product to reach the finished dimensions desired, or as a single piece in any length or shape.

## DEP

Double end panel – Decorative panel placed at the end of run of double depth lockers to conceal the raw edges of the lockers and provides a unified and finished appearance to the run. Edge banded on both long edges. Height is equal to the locker height. Width equals the depth of the locker minus the door(s) thickness. Exception is Double end panel for a sloped top. See below.

## DEP (for Slope Top)

Double end panel – Decorative panel placed at the end of run of double depth lockers to conceal the raw edges of the lockers and provides a unified and finished appearance to the run. Edge banded on both long edges. Height is equal to the locker height plus 12". This is to accommodate the infield cutting of the end panel to match the slope and cover the end. Width equals the depth of the locker minus the door(s) thickness.

## Door(s)

Locker door. Size is determined by frame dimensions. Styles currently available are, slab laminate, Slab veneer, Raised Panel, Flat Panel, Louvered, Full Louvered. Purchasing doors: Order doors full height of locker, less a 1/8 and full locker width less 3/8".

## Filler

Trim piece or pieces used to fill gaps between lockers and a wall, another locker, or to cover an inside corner.

## Frame

This represents a single column of locker(s). Number of lockers in a column is dependent on tier.

## Layout

A plan drawing, or layout, showing dimension, location and orientation of frames within a prescribed space.

## Moulding(s)

Any profile, or decorative wood shape, is called moulding if produced in lineal lengths versus a piece. Mouldings may be made from solid wood, MDF, extruded PVC, or veneer wrapped MDF to look like solid wood.

## Punch List

A list created by the GC or his rep listing all issues with the lockers and their installation. List is made so both parties agree to what is needed and allows for documenting the corrections made and approvals.

## SEP

Single end panel – Decorative panel placed at the end of run of single depth lockers to conceal the raw edges of the lockers and provides a unified and finished appearance to the run. Edge banded on one long edge. Height is equal to the locker height. Width equals the depth of the locker minus the door thickness. Exception is Single end panel for a sloped top. See below.

## SEP (for Slope Top)

Single end panel – Decorative panel placed at the end of run of single depth lockers to conceal the raw edges of the lockers and provides a unified and finished appearance to the run. Edge banded on one long edge. Width equals the depth of the locker minus the door thickness. Take the height and add 12" to accommodate the infield cutting of the end panel to match the slope and cover the end of the locker frame.

## Shelf, Standard

Standard locker shelf is at top and bottom of locker, only. Short .5" in depth for ventilation purposes.

## Shelf, Flush

Used to divide the frame into individual lockers. Unlike the standard shelf it is not shorted for ventilation purposes.

## Tops, Flat

Top will be the full depth of the locker including the door. Edge banded on one long edge. Short side edge banding is determined by location in layout.

## Tops, Sloped

A board with a finished edge installed at an angle between a wall and the top of the lockers. This is to prevent the accumulation of dust and storage of items on top of the lockers.

## Trim, or Base Trim

A 4"H length of finished wood matched to the lockers. Used to cover the unfinished base and create a finished toe kick space. Shipped and sold in 8' lengths. Not sold on every job as any materials can and is used to create a finished base.

## Valance

Decorative treatment used to hide the closet rod and other hardware. It is captured between the frame and below the top. Usually 4" wide and runs the width of the locker. Can be used above the locker as well and if used so will run the width of several lockers per stick.

# Tools and Materials

This section contains a list of basic tools and materials needed for the locker installation. If your lockers have crown moulding you will need additional tools.

## 1.0 Tools



## 2.0 Materials

- 2x4s
- ½"Tx4"W Plywood strips for runners on top of 2x4 frame.
- Wood Screws – 1"
- Wood Glue
- Silicone Adhesive
- Cleaning Solution

# Installation

## 1.0 Base Construction

A base is necessary for proper door function. The standard base is 2x4 with 1/2" plywood top runners and 4"H trim.

### 1.01 Tools and Materials

- 2x4s
- 1/2"Tx4"W Plywood strips for runners on top of 2x4 frame.
- Wood Screws – 1"
- Tape Measure
- Circular Saw
- Drill
- Stud Finder

### 1.02 Determining Size

Base size is determined by subtracting 3" from depth of locker to create toe kick space.

### 1.03 Building

Cut 2x4's.

Use wood screws to build frame.

Attach 1/2"Tx4"W plywood runners on front and back top edge of frame to create decking for lockers.

Spend considerable time leveling the base. Front to back, side to side and plumb. It is easier to level the bases now, then individually leveling the lockers.

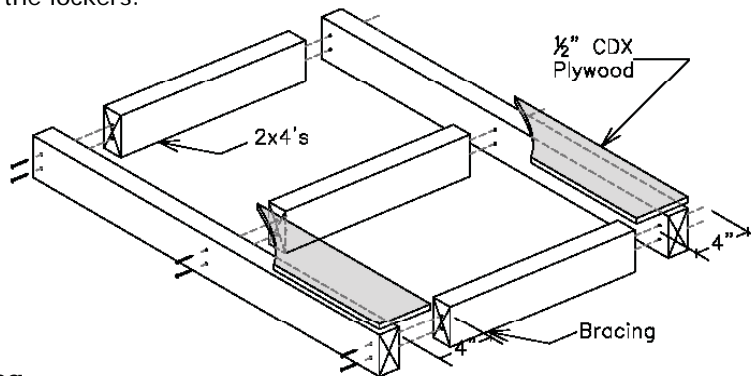

### 1.04 Securing

Base must be secured to prevent tip over. Secure to floor and wall if possible. On a back to back run secure to floor and next base frame. Use appropriate fasteners for the flooring materials. (i.e. tap-con for concrete, wood screw for wood flooring, etc.)

When securing the base to the wall use the stud finder and mark locations of studs above locker height or on base visible from the front. You will need this location when you start securing the lockers to the wall as well.

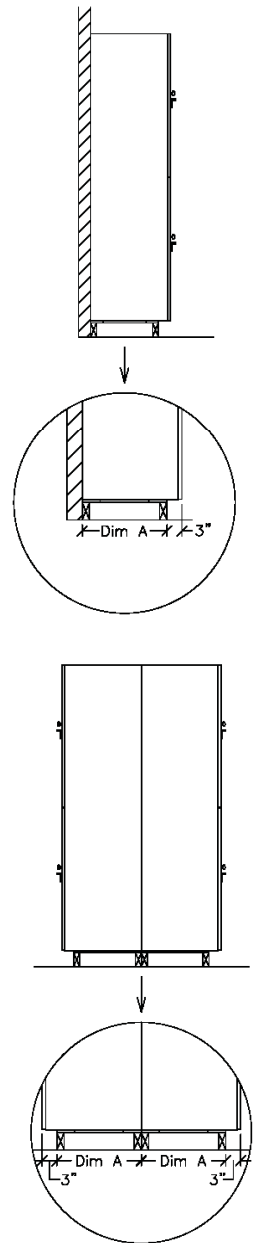

# Installation

## 1.0 Base Construction

### Examples

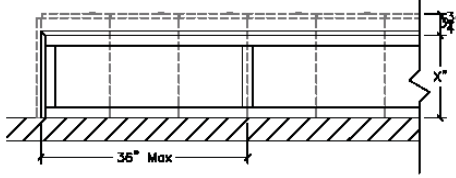

Standard End

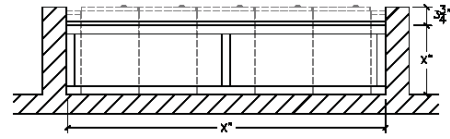

Wall to Wall

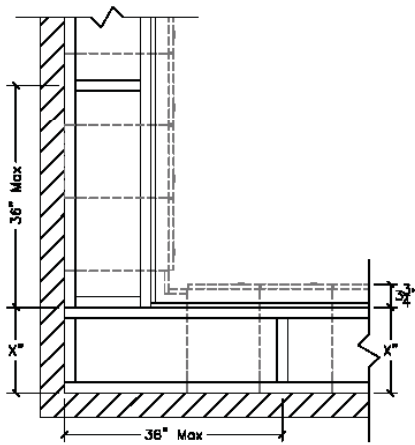

Inside Corner

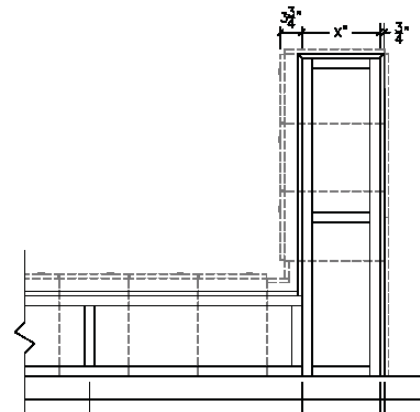

Inside Corner with Back Panel

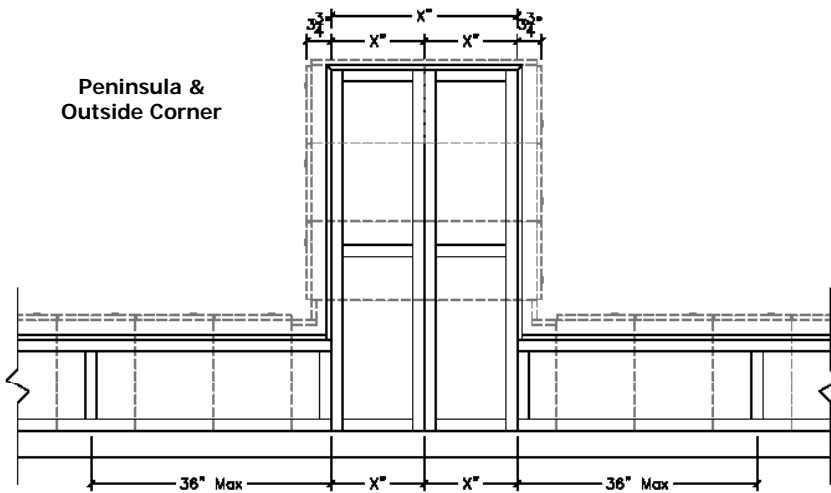

Peninsula & Outside Corner

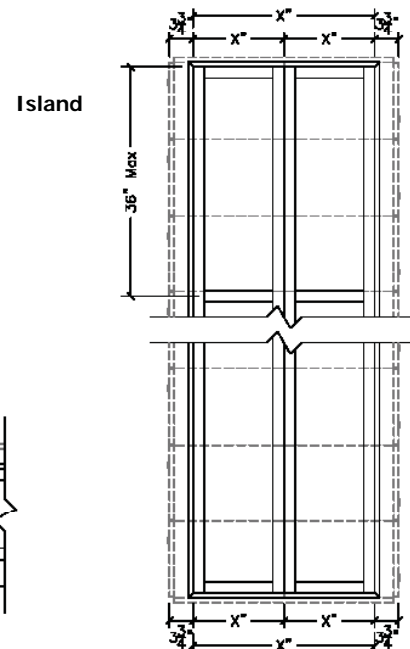

Island

# Installation

## 2.0 Unloading

The size of a locker order determines the shipping methods. The two most common are listed below, floor loaded and palletized.

Upon delivery of the lockers inspect them. Record any damage on Bill of Lading and have the driver sign it as well. You have a very short window of time to report any freight or other damage.

It is always best to minimize handling of the lockers. The more they are handled the more risk for damage. So if you can, take them straight from the loading dock to the room where they will be installed.

### 2.01 Tools and Materials

- Hand Truck
- Furniture Dolly
- Blankets or padding

### 2.02 Floor loaded

The easiest way to unload floor loaded lockers is to use a hand truck or furniture dolly, one at a time.

Cut the banding holding the order together and start unloading. Inspect the lockers, record and report all damage.

Using hand trucks or furniture dollies, with padding, take to the installation area and set lockers in place.

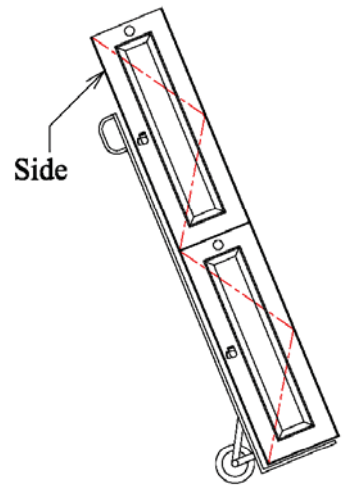

### 2.03 Palletized

As the name suggests the lockers will arrive on a pallet designed for forklift or pallet jack.

If you can, keep everything on the pallet for as long as possible and use a pallet jack or forklift to get the pallet to the work area. This will minimize handling and risk of damage. However, you still must inspect the lockers upon delivery. Record any damage on Bill of Lading and have the driver sign it as well. You have a very short window of time to report any freight or other damage.

After you have gotten the pallet as close as possible cut the banding, use hand trucks and furniture dollies, with padding, to move to the final destination, the same as floor loaded.

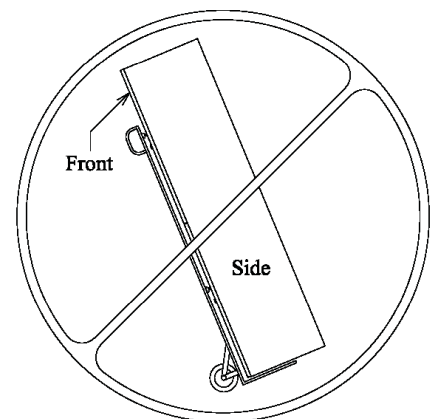



# Installation

## 3.0 Connecting Lockers

As mentioned in prior sections lockers need to be secured to prevent tip over. Part of that process is connecting the lockers together with connector bolts.

### 3.01 Tools and Materials

- Rubber Mallet / Hammer
- Flat head screwdriver
- Clamp
- Connector bolts

### 3.02 Process

During base construction care was taken to level the base front to back, side to side and plumb. You should be able to set each locker side by side and start connecting with minimal, if any, additional leveling.

The connector bolt is a two piece bolt, commonly referred to as either a sex bolt or a male/female bolt. When facing the locker the male side of the connector bolt goes on the left side of the locker frame. The female goes into the right side of the adjoining frame. See example.

Once the lockers are arranged and placed on the base, use the provided connector bolts to attach the frames together. Insert the connector bolts into the pre-drilled holes, 4 per frame per side. Hand tighten the bolts and then use a screw driver for snug connection.

Do not over tighten. You can strip the female side of the connector and you could cause the frame to bow at the connection points.

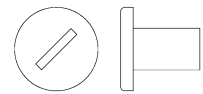

"Female"

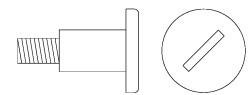

"Male"

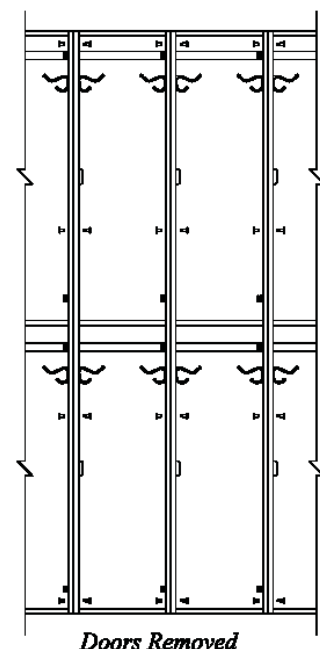
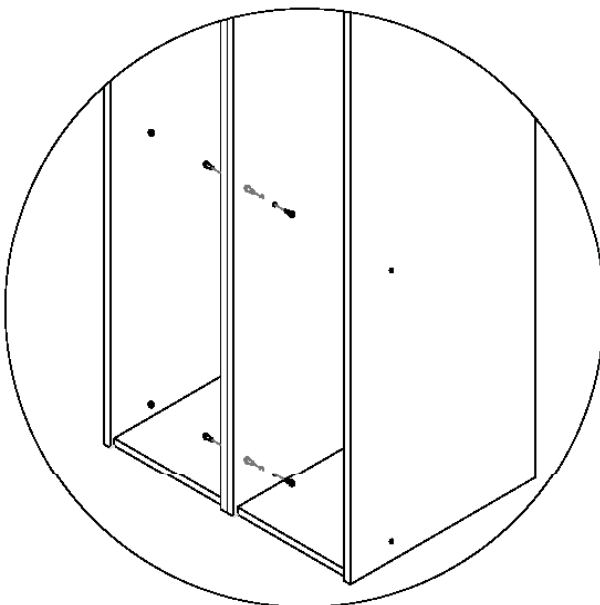

# Installation

## 4.0 Securing Lockers

Lockers need to be secured to prevent tip over. Part of that process is connecting the lockers together with connector bolts and part is securing the lockers to the base and the wall.

### 4.01 Tools and Materials

- Drill
- Wood Screws – 1"
- Cover Caps

### 4.02 Process

Once lockers are connected to each other they must then be secured to the base and the wall. At a minimum you must do this every 3<sup>rd</sup> or 4<sup>th</sup> locker.

In previous steps stud locations were marked either on wall above locker height or on base.

During base construction care was taken to level the base front to back, side to side and plumb. You should be able to start securing with minimal, if any, additional leveling.

To attach to the wall, pre drill a hole in the back of the locker and attach locker to stud with a screw.

To attach to the base, pre drill a hole in the bottom of the locker and attach the locker to the base with a screw. Use provided cover caps to conceal the screw heads on the inside of the locker.

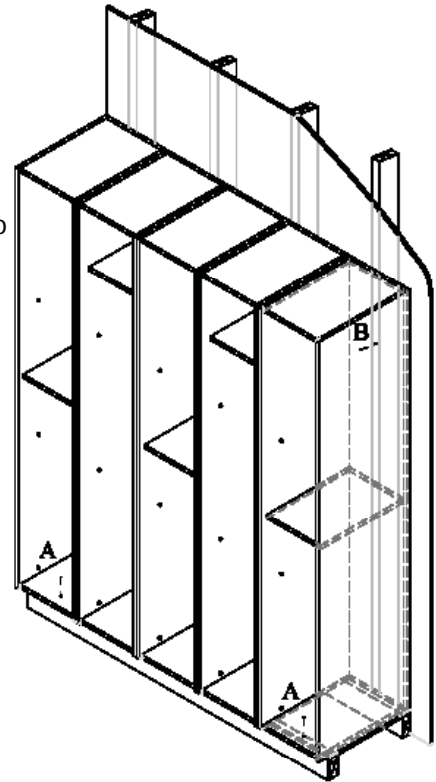

*Doors Removed*

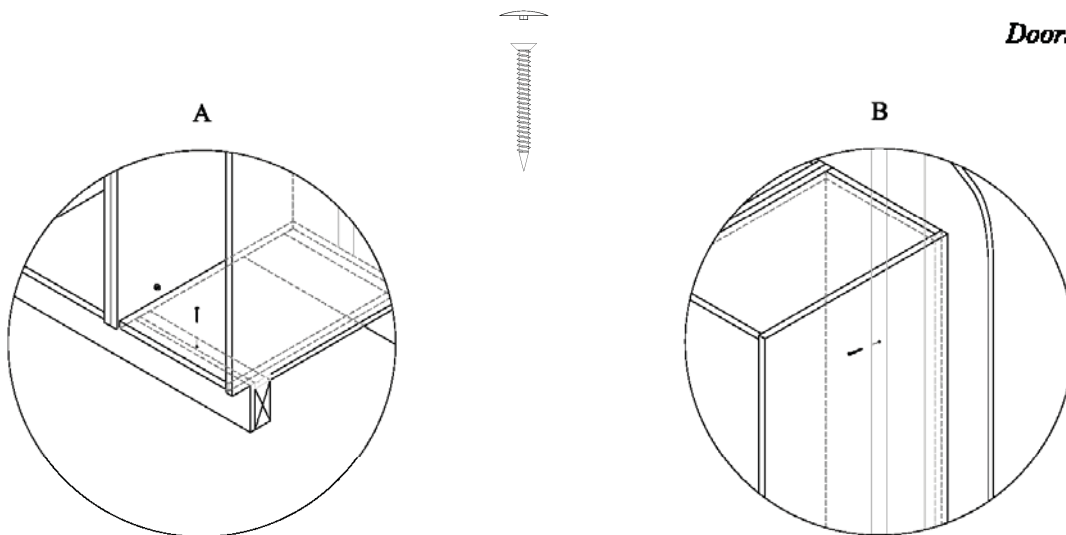

# Installation

## 5.0 Filler Panels

Filler panel is used to bridge the gaps between locker frames & wall and frame to frame on an inside corner.

### 5.01 Tools and Materials

- Drill Circular Saw
- Wood Screws – 1"
- Tape Measure

### 5.02 Process

Complete steps 3 and 4 prior to installing your filler panel.

#### Frame to wall

Measure the distance between the frame and the wall cutting your filler panel to that dimension. Attach mounting blocks to the back of the filler panel so you have a means of attaching the filler to the wall. Use screws to attach to the wall. From the inside of the locker frame attach the filler to the frame.

#### Inside corner

Typical installation is a 90 degree inside corner. Measure and cut your two piece filler. Attach your blocking if desired first then the two pieces to each other using a standard butt joint. Insert this corner filler into the inside corner. Using screws and predrilled holes attach the filler to the frames from the inside of the locker frame.

Now that the filler is in place you have to cover this corner hole. Otherwise it will become a receptacle for trash, debris and lost items. Using materials on hand, install blocking on the walls and frame below the line of sight. Make a cover, of drywall or plywood, and secure it to the blocking using screws.

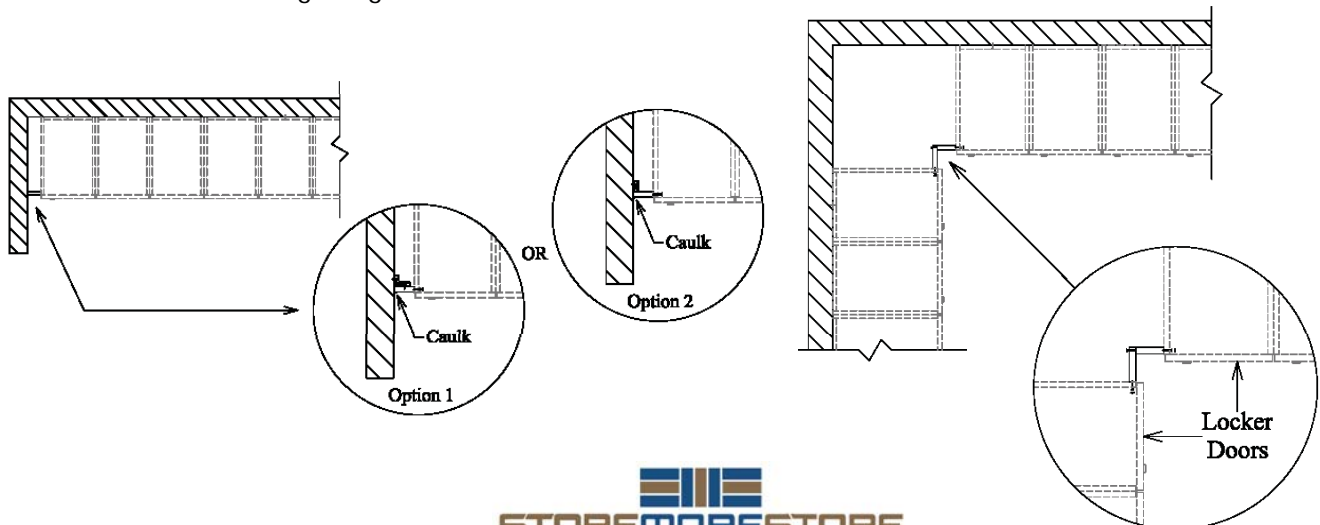

# Installation

## 6.0 End Panels

End panels are decorative panels placed at the end of run of lockers to conceal the raw edges of the lockers and provides a unified and finished appearance to the run.

### 6.01 Tools and Materials

- Drill
- Wood Glue
- Wood Screws – 1"
- Cover Caps

### 6.02 Process

Attach end panels at the end of each run of lockers to conceal the exposed end. Before attaching the end panel, apply wood glue to the backside of the end panel for additional holding power. See the illustration on the right with indicates where to pre-drill the locker frame and attach the end panel. Install crews from inside as shown. Once the end panel is secure – apply matching interior cover caps to the exposed screw heads.

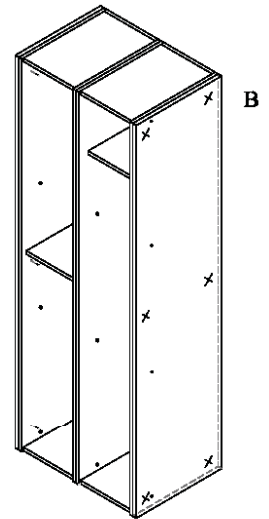

#### Note:

Do not use the pre-drilled connector holes for the end panel attachment

#### Note:

When installing either raised panel or flat panel end panels the screw must go into the stile and not the center panel. See illustration for common screw locations.

#### Warning:

Do not use screws longer than 1" when installing the end panels. Any longer and screw may penetrate the end panel.

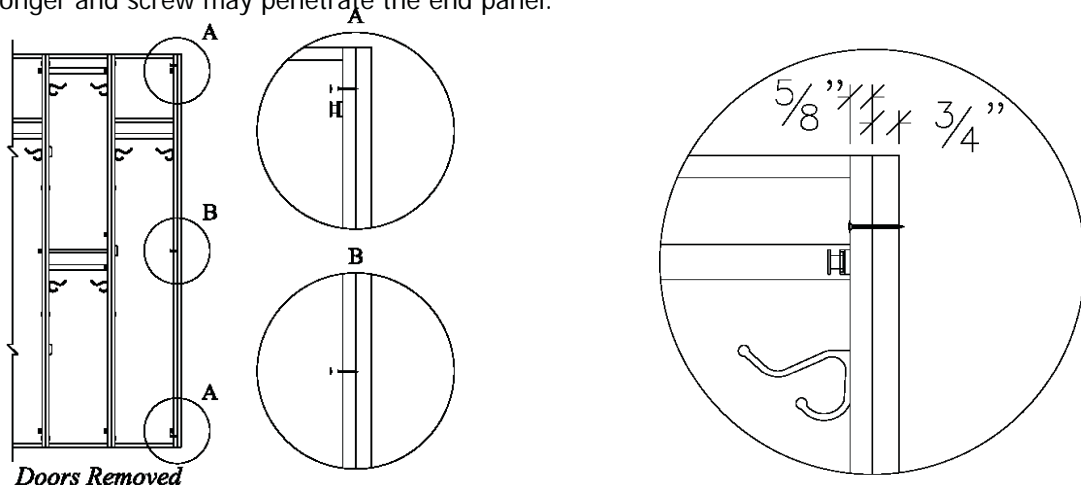

# Installation

## 7.0 Crown Moulding and Valance

Crown and valance are decorative and provide a finished appearance to the lockers.

### 7.01 Tools and Materials

- Drill
- Wood Glue
- Wood Screws – 1"
- Cover Caps

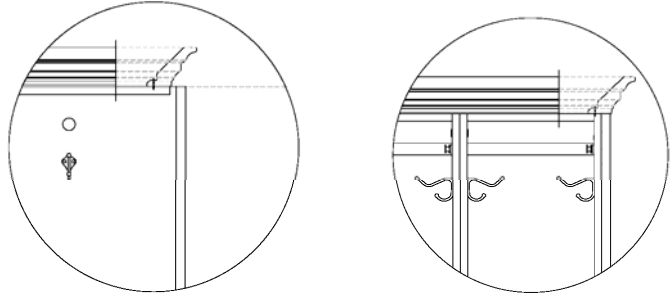

### 7.02 Process

The Legacy Lockers standard crown is designed to sit set back behind the door, just slightly overhanging the top of the locker. On the sides, ends, it is to slightly overhang the end panels.

There are many methods and tools used each with their own set of instructions. These instructions are written for the use of a miter saw. Review illustrations, drill locations and tool instructions prior to starting crown installation. In addition there are many helpful videos on the web available for viewing. Such as <http://www.youtube.com/watch?v=3PIIj2afKU>

Installing crown can be demanding. So take your time. Read your instructions. Watch some videos. Practice on a small piece before making your finish cuts. Measure twice.

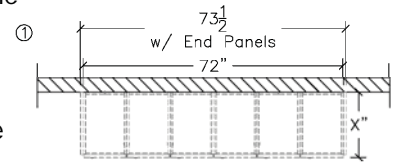

Most crown installations consist of a straight run, inside corner or an outside corner. Most rooms would have 4 inside corners. Most lockers will have mix of inside and outside corners depending on your room layout.

#### Inside Corner

The corner is made up of two components, a left and a right. To make the right component, put the piece of crown upside down, with the finished side to you, on the **left** side of the saw. Turn the blade to the 45 degree stop on the **left** side. Make your cut.

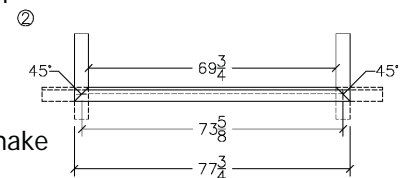

To make the left component, put the piece of crown upside down, with the finished side to you on the **right** side of the saw. Turn the blade to the 45 degree stop on the **right** side. Make your cut.

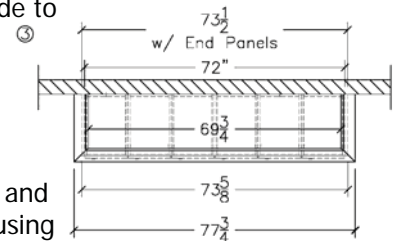

See examples 1 thru 3 to determine you length of cut.

Attach the crown around the top perimeter of the locker. Use glue and screws. Pre-drill. Use only 1" screws only. Screw from top down, using the 1/2" flange on the back of the crown, into locker frame only. Do not screw into top of locker just locker frame.

# Installation

## 7.0 Crown Moulding and Valance *Continued*

### 7.02 Process *Continued*

#### **Outside Corner**

The corner is made up of two components, a left and a right.

To make the right component, put the piece of crown upside down, with the finished side to you, on the **left** side of the saw. Turn the blade to the 45 degree stop on the **right** side. Make your cut.

To make the left component, keep the piece of crown upside down, with the finished side to you on the **right** side of the saw. Turn the blade to the 45 degree stop on the **left** side. Make your cut.

In example one the distance of the locker run is 73 ½". Your distance between cuts will be 69 ¾".

Align with your pencil mark at 69 ¾" and make your cut. This takes care of the face piece of trim. Do the same for the returns except one end will be a butt cut as it will be flush with the wall.

Attach the crown around the top perimeter of the locker. Use glue and screws. Pre-drill. Use only 1" screws only. Screw from top down, using the ½" flange on the back of the crown, into locker frame only. Do not screw into top of locker just locker frame.

#### **Wall to Wall**

Use any saw as no miters are involved. Measure the length of the locker run. Cut square or butt joints as there is not return.

Attach the crown around the top perimeter of the locker. Use glue and screws. Pre-drill. Use only 1" screws only. Screw from top down, using the ½" flange on the back of the crown, into locker frame only. Do not screw into top of locker just locker frame.

#### **Valance**

Use any saw as no miters are involved. Measure the length of the locker run. Cut square or butt joints for the inside and outside corners, as you would for filler. Attach to lockers by screwing into the valance from inside the locker. Or, apply blocking to the valance and screw from the top, through the blocking into the locker frame as you would for crown. This is the preferred method as it is cleaner in appearance to the user and provides support for the valance.

# Installation

## 8.0 Slope Top

The purpose of slope top is two fold. To act as a dust cover for the top of the lockers and to prevent users from placing trash or other objects on top of the lockers. Legacy slope top is made as panels that can be custom fit in the field. The panels allow the end user to determine what angle is most desirable for them, not preset.

### 8.01 Tools and Materials

- Drill
- Circular Saw
- Wood Screws – 1"
- Cover Caps

### 8.02 Process

Typical slope top height is 1/3 the locker depth:

12"D = 4"H

15"D = 5"H

18"D = 6"H

20"D = 7"H

Determine the height you wish the slope to be and that will determine the angle.

Rip your nailer, usually a 2x4, to that angle. Attach the 2x4 to the wall using AWI Standard methods. This will support the back edge of the slope top. Determine the width of your slope top by measuring from the wall, above the nailer, to the front edge of the locker behind the door. See illustration. Rip the panels to that width. Attach by pre-drilling and screwing from the top into the nailer and from the inside of the locker to the front edge of the slope top. Cover inside screws with cover caps.

If there are end panels you must cut the length of the slope top to cover the end panel. Once the slope is on you can then scribe the end panel to fit under it.

Inside and outside corners are handled the same way as any trim or crown.

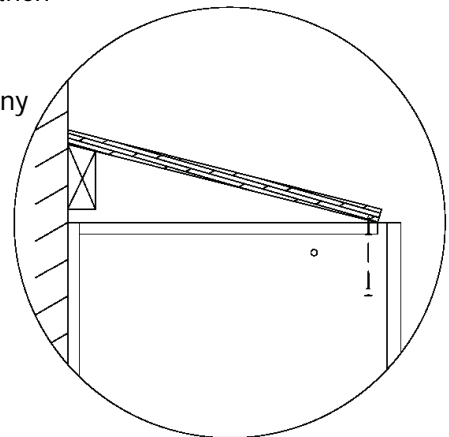
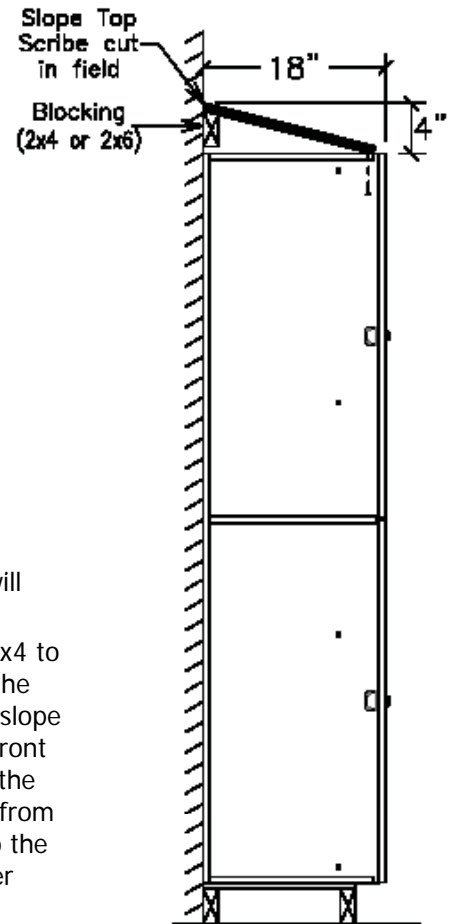

# Installation

## 9.0 Number Discs

Each locker door will have some type of identification. This can vary with order but the most common is a routed recess for a number disc. Number discs are applied in the field as this method is the easiest for the installer. Number discs are found in your hardware kit.

### 9.01 Tools and Materials

- Silicone adhesive
- Number discs

### 9.02 Process

Before starting review you layout or number plan to ensure that you understand the sequence and location of all numbers. Each job and the numbering is different. If there is no numbering plan start at a door way, go clockwise, and number all lockers.

Apply a small amount, less than a pea size, in each routed disc recess. Press the number disc into the recess. This will adhere the disc to the locker. Make sure the numbers are level before moving on. Do not make any adjustments once the silicone starts to bond and set up. Doing so will stop the adhesion and the number disc will, over time, become detached.

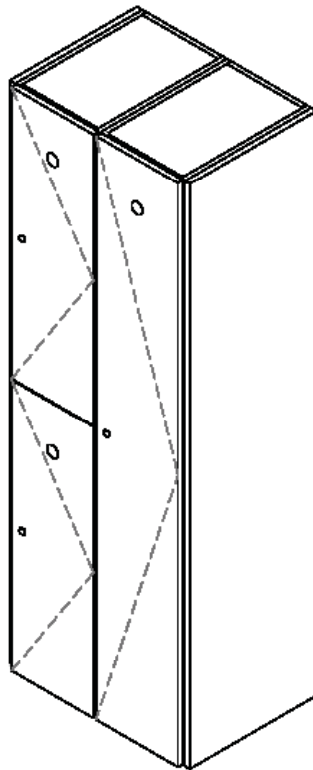



# Installation

## 10.0 Hinge Adjustment

The hinges can be adjusted 5 ways. **Left** and **Right** on the door side of the hinge. On the frame side is **Up**, **Down** and **Front to Back** (Depth)

### 10.01 Tools and Materials

- Screwdriver: Philips or Pozidrive

### 10.02 Process

Lockers are fabricated individually and shipped assembled. This means that while the doors were adjusted in the factory that they have been handled multiple times since and will require a final adjustment in the field.

See illustration below for adjustments and adjustment locations.

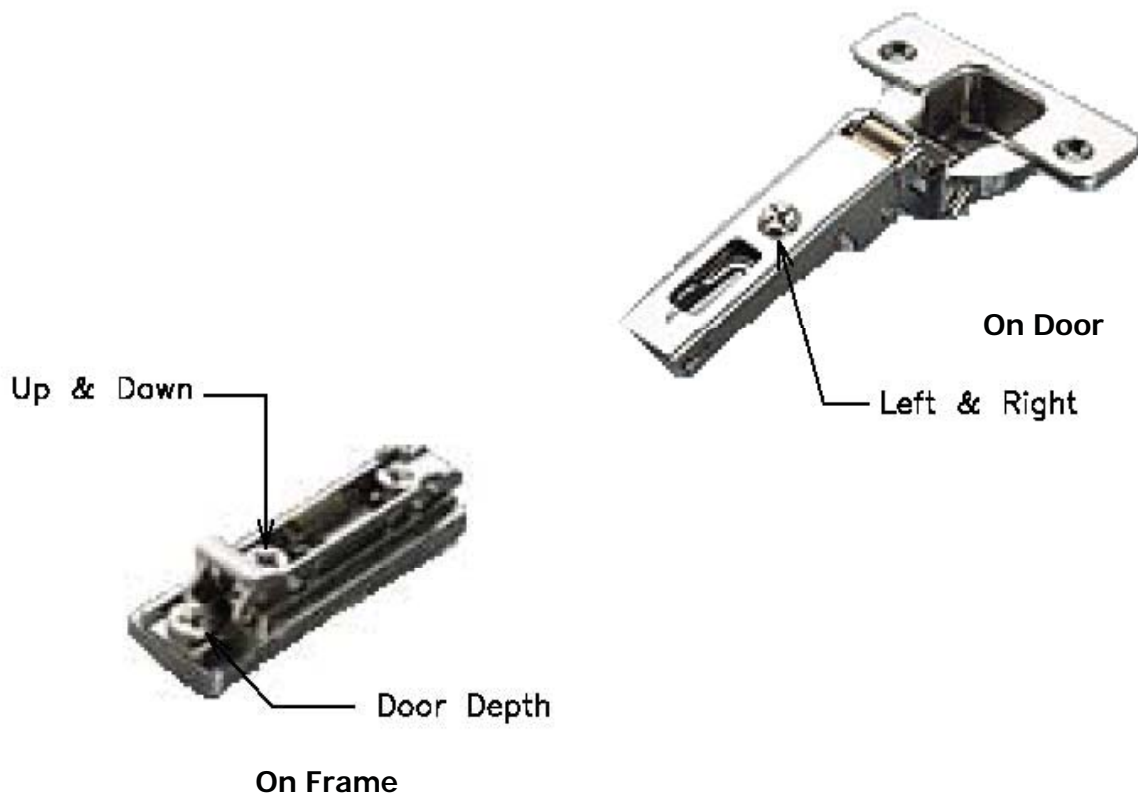

# Installation

## 11.0 Base Trim

Base trim is a decorative element added to conceal the unfinished base. It can be many different items and may or may not be part of the locker order. It can be standard plastic cove base, tile, carpet or matched to the lockers.

### 11.01 Tools and Materials

- Staple gun (Carpet install)
- Wood Glue or Silicone adhesive

### 11.02 Process

Only two types of trim will be discussed here. Carpet and matched trim.

#### Carpet

To finish the base with carpet, cut the carpet to match height of base.

Run carpet up base under locker and staple as high on base as possible.

#### Matched

As the lockers can be made from many materials the matched base trim will be as well.

The most common attachment method is silicone adhesive. This is effective on most surfaces; melamine, laminate, veneer or pvc. Cut the trim to length. Use butt joints where necessary. Apply a generous amount of silicone to the back of the trim. Apply to the base, holding briefly until silicone starts to set up. In most cases trim nails or screws will not be necessary. If you must use them do so as high up on the base as possible to keep out of sight.

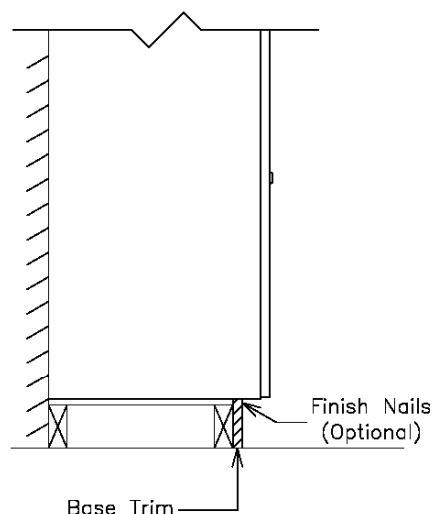

# Care and Cleaning

## Interiors

Clean lockers interiors with a mild soap and warm water. Use as little water as possible. Dry with a clean soft cloth immediately.

For sticky or heavy residue, inside or outside of locker, clean up with a warm, mild solution of Murphy's Oil Soap or equivalent. Dry with a clean soft cloth immediately.

Do not use strong detergents, abrasives or chemical agents to clean your lockers

## Laminate / Foil / RTF Doors

Clean doors with a mild soap and warm water, such as Simple Green. Dry with a clean soft cloth immediately.

## Wood Doors

Test in an inconspicuous place, first, before using any cleaning product. Some cleaning products can affect the finish.

Lemon Oil, Cabinet Magic and quality furniture polishes can be used on the wood doors to clean and maintain them.

Use Old English Scratch Cover, or a paste shoe polish, to touch up scratches.

Your wood door is not a towel holder. Do not drape wet towels over the doors.

Do not use wax. Over time the wax will cause a film to build up which attracts dirt.

Do not use silicone based polishes.