

Assembly Procedure

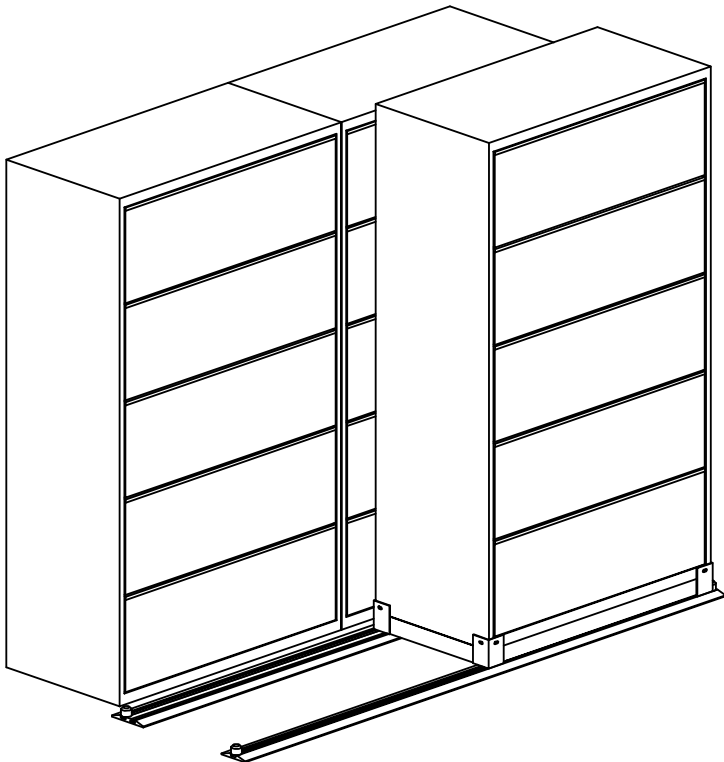
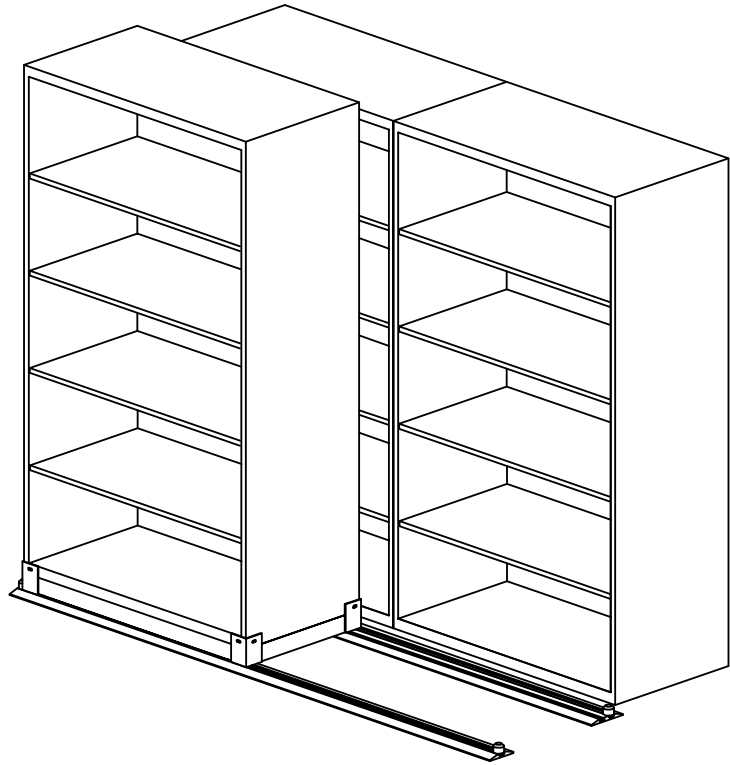

STOREMORESTORE.COM

www.StoreMoreStore.com | 855-786-7667

INSTALLATION

We recommend the removal of all carpet and padding prior to installing. We suggest that carpet be removed the length and width of each track. Product performs best when installed on concrete or tile. NOTE: We cannot assure proper leveling if track is installed on low-pile carpet.

- Read all instructions before attempting assembly.
- Check floor plan layout. Measure and mark floor for intended layout, preplan exact location of all units with regard to columns, lights, windows and obstructions.
- Check levelness of floor in the proposed install area.
- Due to floor variations, additional shim material (Masonite) may need to be purchased locally by installer.

GENERAL NOTES:

1. Installation begins with the layout of the floor plan. It is imperative for the proper operation of this system that the tracks be parallel, level and square. The MLTA track, with the In-track Anti-tip safety feature, is located at the rear.

2. The carriage with the anti-tip guide is designed to be inserted onto the MLTA track after that track is in the approximate location, but prior to completely securing it to the floor. This will eliminate the need to disassemble the guide from the carriage.

3. The carriage is shipped completely assembled. If the carriage with the anti-tip guide assembly cannot be inserted into the MLTA track, it is possible to remove and reinstall the mount assembly. Loosen 1/4" bolts and remove anti-tip mount(s). Place carriage on track. Care must be taken to properly place the mount(s) tightly to the channel and angle of the carriage during re-assembly. Re-use fasteners.

4. **The KTTV track kits are pre-packaged to include mounting hardware, end stops and shim material. If KTTV track kits are used in conjunction with each other to obtain longer track runs, insert the roll pins of one track into the other.** This will insure proper track alignment.

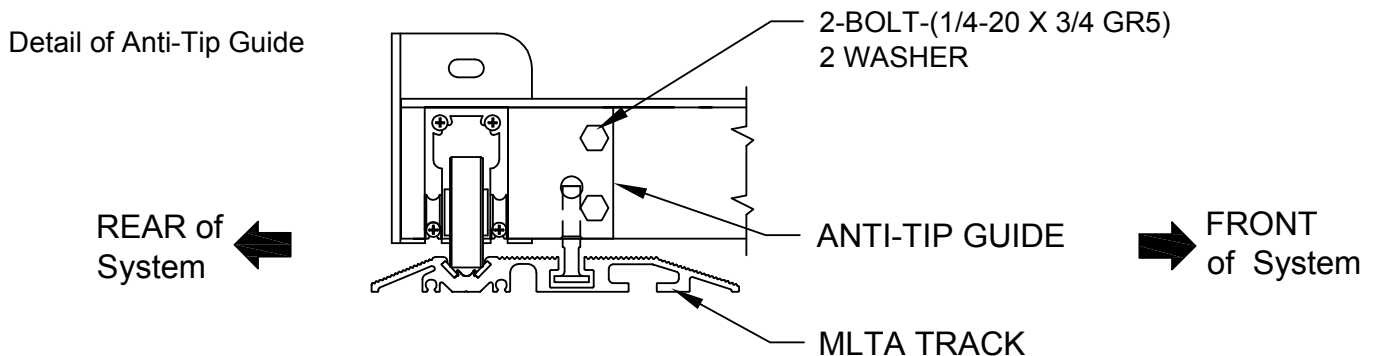

5. Required tools:

- hammer drill (concrete drill bits are provided in the hardware bag)
- cordless (or electric drill motor) / Phillips screw adapter
- flat and Phillips screwdriver
- 9/16" socket
- hammer
- measuring tape
- chalk line
- level (360 Degree Rotary Laser Level is best suited)

The In-track Anti-Tip track (MLTA) will be shipped with the Heavy-duty track (MLT).

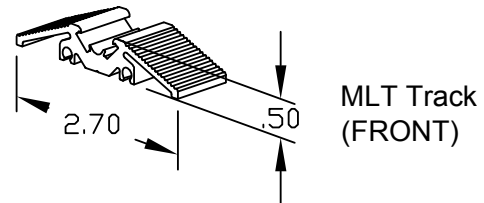
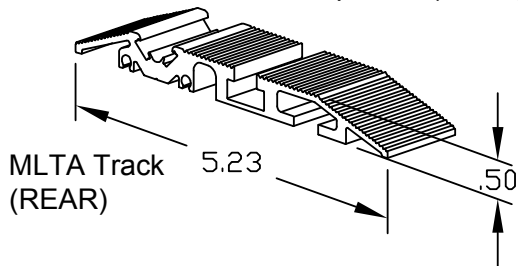

- Install Stationary Shelving per 'Typical Stationary Placement' drawing on Page 4.
- Use stationary shelving to assist in aligning track and mobile carriages. The tracks should extend beyond the stationary shelving at equal dimensions on either side.
- Align assembled track parallel to stationary shelving or aisle with approximately 2" clearance from any obstacle. The MLTA track will be the 'REAR' track of the two track lateral system. Using the holes in the track as a guide, drill 1/4" dia. holes into the concrete floor deep enough for the track end fasteners. Clean concrete dust from holes. Level track using shims provided. The track must be supported along its entire length.

● **INSTALL END STOP ON ONE END OF MLTA TRACK.**
BE SURE TEE NUT FOR OPPOSITE BUMPER IS UNDER TRACK PRIOR TO FINAL TRACK ANCHORING.

- Hammer the fastener(s) into the floor through holes in both ends of track.
- Confirm joints are still properly seated, track is straight and level.

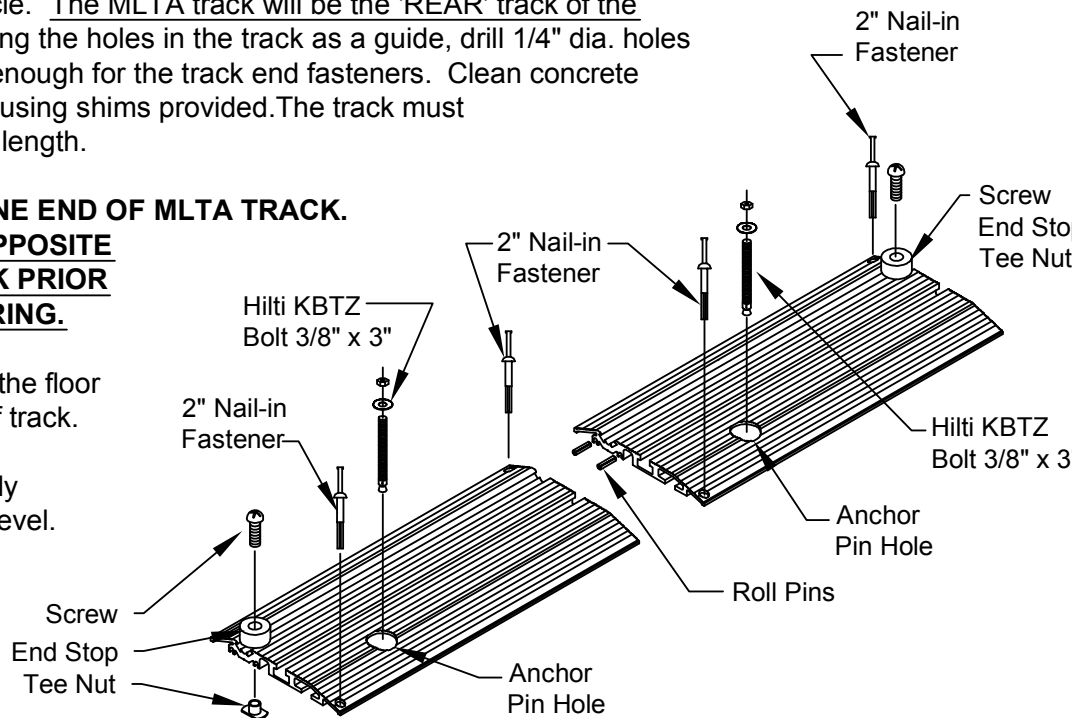

- Maintaining careful alignment of the MLTA, drill a 3/8" hole into the floor and install the mid-track 3/8" x 3" HILTI KBTZ Concrete bolts at every available anchor point in the track. The strength of the anti-tip is in the anchors. Make sure they are tightened properly.
CAUTION: Hole depth for 3/8" HILTI bolt must be a consistent depth as to prevent tripping hazard.
- Once the anti-tip track is secured, the remaining tracks can be set in the approximate location.
- Place one carriage on the track to determine spacing. Verify carriage wheels are centered in the channels and in the track.
- The tracks must be square, parallel, and level to each other to insure proper operation. Measure each set of tracks and the entire system, corner to corner, to verify that each distance is the same. Once each cross measurement is the same, the system is square and parallel.
- When the tracks are square, parallel, level and shimmed as required drill the end holes. Install remaining anchors. It is the installer's responsibility to verify smooth operation of the system.
- Place the remaining carriages on the track, verify smooth operation and install the remaining end stops on MLT and MLTA tracks.

- Install the shelving per the manufacturer's specifications. Secure to the mobile carriage with TEK screws through corners/center plates. TEK screws are found in the accessory box.
- Install cabinets to the Mobile CarriageTM with TEK screws through corners/center plates, TEK screws are found in accessory box.

NOTE: LATERAL FILE CABINETS require that all glides remain installed with the REAR glides turned in all the way. Proper glide adjustment must be made per instructions supplied with cabinet. When installed on the carriage surface, the lateral file cabinet front should be 1/8" higher than the cabinet rear.

