

STORAGE CABINET Assembly Instructions / Parts Manual

READ INSTRUCTIONS CAREFULLY BEFORE BEGINNING CABINET ASSEMBLY.

Retain instructions for future parts ordering.

Description

Hallowell storage, wardrobe and combination cabinets are designed to provide secure storage for office supplies, books, tools, office machines, etc. in offices, schools, institutions, business and industrial store rooms.

The cabinet handle is supplied with a built-in lock and two keys. the cabinet has a three point locking system with lock bars located in nylon guides for quiet operation.

Model 815 is a storage cabinet that has four adjustable shelves for storage.
Model 835 is a wardrobe cabinet with one hat shelf and a 36" coat rod.
Model 855 is a combination wardrobe and storage cabinet with one hat shelf, an 18" coat rod and 4 adjustable 18" wide shelves.

Specifications

Overall dimensions:

Model 815, 835, 855 are 78" high by 36" wide by 18" or 24" deep.

Basic construction:

Shelves, sides, rear, doors, top & bottom are 20 ga. steel.
Frames are 16 ga. steel.

Approximate shipping weights:

Model 815-S-18160 lbs.	Model 815-S-24184 lbs.
Model 835-W-18143 lbs.	Model 835-W-24157 lbs.
Model 855-C-18167 lbs.	Model 855-C-24220 lbs.

Color: Parchment only, Shelf adjustment increments2"

ASSEMBLY INSTRUCTIONS

(All Models)

Tools Required: 3/8" nut driver, slotted screwdriver, rubber mallet.
Do NOT tighten bolts until cabinet is completely assembled.

- 1. Place rear panel (item 5) on either padded horses or on protected floor with flanges upward.**
- 2. Attach side panels (items 7) with the flange under the rear panel offset with 10-24 x 3/8" bolts and nuts. The bottom support strips should be at the same end and shelf adjustment strips pointed in the same direction.**
- 3. Place a shelf (item 8) into shelf adjustment strips to hold sides in upright position while attaching top (item 6) .**
- 4. Place door frame assembly (item 1 . 2 . 3) on top of assembly and bolt to top and side panels.**
- 5. Position bottom (item 4) into offset support strips on sides and rear. Front flange of bottom must fit over front flange of frame and be bolted with 2 bolts from the outside (tighten) .**
- 6. If model 855, install center divider (item 11 fig. 3) tighten bolt to bottom.**
- 7. Bolt 4 cabinet foot braces (item 13) to frame and sides and rear (tighten) . All models.**
- 8. Stand cabinet upright, be sure cabinet is level and doors close properly then tighten all bolts.**
- 9. Insert one side of adjustable shelf (item 8 or 12) at desired position then move other side up to the same position. If model 835, bolt coat rod (item 9) inside the flanges of shelf with bolt heads outward. Insert in top location. Seat all shelves with mallet.**
- 10. Using rubber mallet tap nylon rod guide (item 15) into top and bottom flanges of right door (item 2) .**
- 11. Install locking handle (item 24) to right door with #8-32 bolts (item 19) see door handle detail. Place lock cam (item 17) on back of handle with pins out. Insert lock rods (item 16) into rod guides and position holes in lock rods on pins of lock cam. Secure in place with cam keeper (item 18) using 8-32 flat head screw (item 20) .**

CABINET PARTS

	MODEL 815		MODEL 835		MODEL 855		
ITEM	DESCRIPTION	815-S-18	815-S-24	835-W-18	835-W-24	855-C-18	855-C-24
1	LEFT DOOR	ICLD3678	ICLD3678	ICLD3678	ICLD3678	ICLD3678	ICLD3678
2	RIGHT DOOR	ICRD3678	ICRD3678	ICRD3678	ICRD3678	ICRD3678	ICRD3678
3	DOOR FRAME	ICHFA78	ICHFA78	ICHFA78	ICHFA78	ICHFA78	ICHFA78
4	BOTTOM	ICB3618	ICB3624	ICB3618	ICB3624	ICB3618	ICB3624
5	REAR PANEL	ICR3678F	ICR3678F	ICR3678F	ICR3678F	ICR3678F	ICR3678F
6	TOP	ICT3618	ICT3624	ICT3618	ICT3624	ICT3618	ICT3624
7	SIDE PANEL	ICS1878F	ICS2478F	ICS1878F	ICS2478F	ICS1878F	ICS2478F
8	36" SHELF	ICAS3618	ICAS3624	ICAS3618	ICAS3624	ICAS3618	ICAS3624
9	36" COAT ROD			ICCR36	ICCR36		
10	18" COAT ROD					ICCR18	ICCR18
11	CENTER DIVIDER					ICD1878	ICD2478
12	18" SHELF					ICAS1818	ICAS1824
13	CABINET FOOT	CFP100	CFP100	CFP100	CFP100	CFP100	CFP100
14	COUNTER TOP						
15	ROD GUIDE	LRG 1	LRG 1	LRG 1	LRG 1	LRG 1	LRG 1
16	LOCK ROD	ICLR78T	ICLR78T	ICLR78T	ICLR78T	ICLR78T	ICLR78T
17	LOCK CAM	*					
18	CAM KEEPER	*					
19	8-32 RD HD BOLT	*					
20	HINGE PIN	*					
21	PLATE						
22	TURN HANDLE	CH100A	CH100A	CH100A	CH100A	CH100A	CH100A

ITEMS 17, 18, 19, 20 INCLUDED WITH TURNHANDLE

- o 10-24x3/8 bolt MBT200
- o 10-24 nut N201
- o Not shown

* Included with handle or available locally. (standard hardware)

MDS/CAS 1/6/94 * JMH 11/19/04



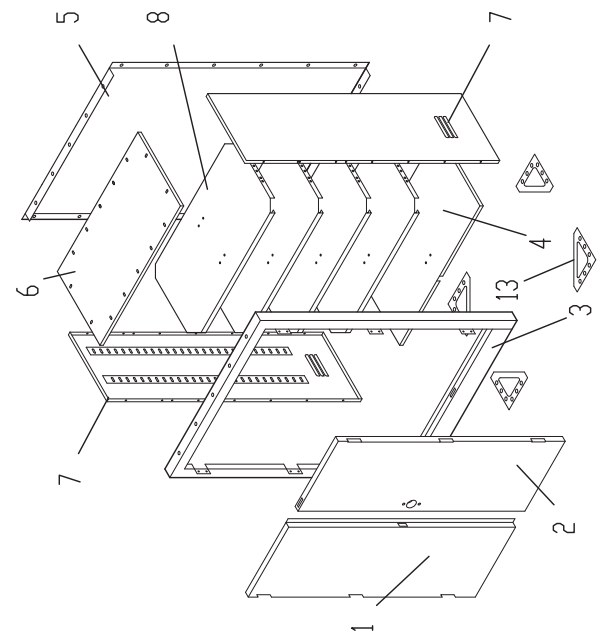

#815 - STORAGE

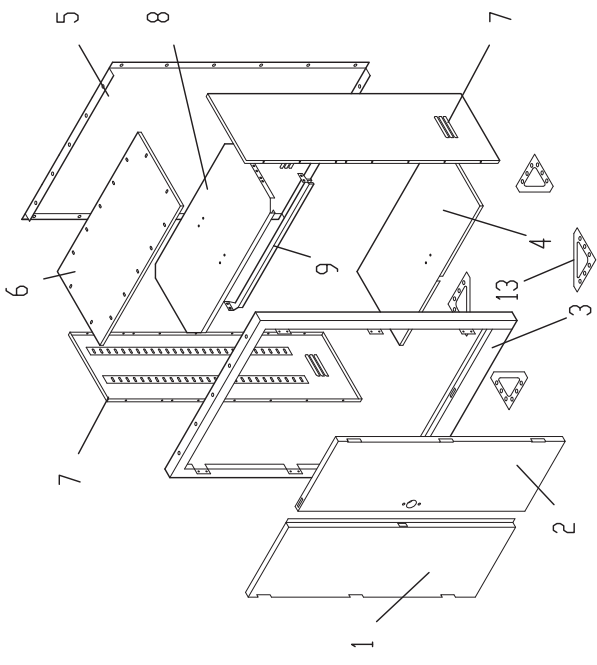

#835 - WARDROBE

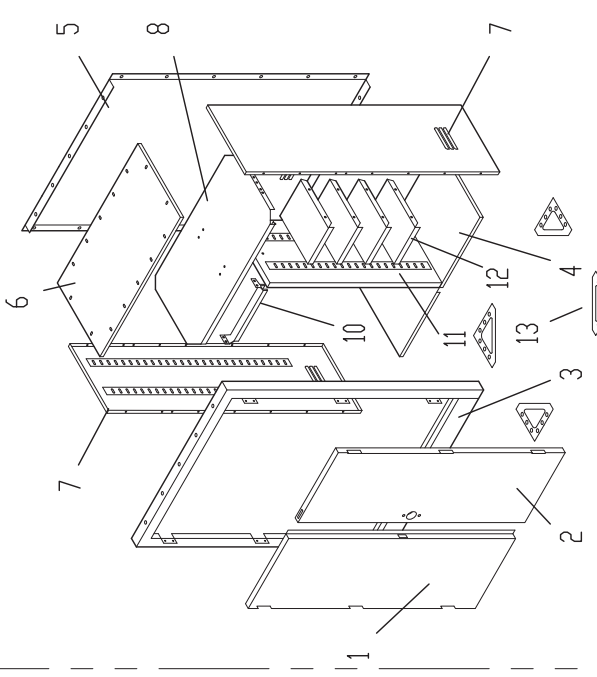

#855 - COMBO

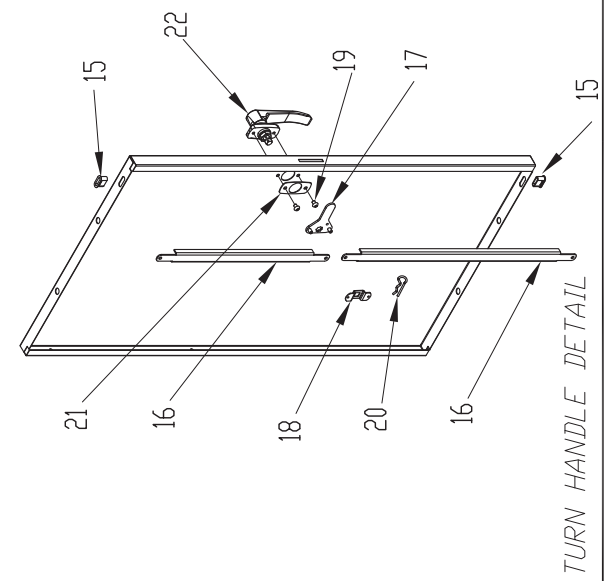

TURN HANDLE DETAIL

LEGEND:

- 1. LEFT DOOR
- 2. RIGHT DOOR
- 3. FRAME
- 4. BOTTOM
- 5. REAR PANEL
- 6. TOP
- 7. SIDE PANEL
- 8. 36" ADJ. SHELF
- 9. 36" COAT ROD
- 10. 18" COAT ROD
- 11. DIVIDER
- 12. 18" ADJ. SHELF
- 13. FOOT BRACE
- 14. CHANNEL GUIDE
- 15. LOCK CHANNEL
- 16. LOCK CHANNEL
- 17. TEE
- 18. CAM
- 19. #8-32 SL PANHEAD KEP
- 20. #8-32 PH FLATHEAD
- 21. TURNHANDLE



STOREMORESTORE
 Efficient Productive Storage Products
 1-855-786-7667
WWW.STOREMORESTORE.COM

△ CHANGE FROM ASSY RIVET TO SCREW USED WITH CSK CAM

TOLERANCES	
UNLESS NOTED,	
3 DECIMAL ±.005"	
2 DECIMAL ±.010"	
FRACTION ±1/64"	
90°/ANGLE ±1/2°	