

# FORMS/STORAGE CABINETS

---

## A. TOOLS REQUIRED

- Phillips head screwdriver (door installation -- cabinets with doors only)
- Level

## B. CABINET SET-UP

1. Place cabinet on its back or side on a non-abrasive surface.
2. Find leveling glides taped inside cabinet. Locate glide holes on the bottom near corners of each cabinet. Insert glides; turn clockwise until tight.
3. Turn cabinet upright and set in place.
4. Adjust glides as necessary to level cabinet as necessary.

## C. CONFIGURATION INFORMATION

### 1. If your Forms/Storage Cabinet:

- is a preconfigured model (no "X" in the model number), see chart on page 3 for the component and shelving configuration for your model. (Find the model number from the carton marking or shipping documents.
- has been specially configured for the customer (model number has an "X" in it), information about component and shelving information must be obtained from the customer or specifier who created this special configuration.
- has shelving top to bottom, with no Master Shelf (6th digit of the model number on preconfigured cabinets is a "B" or "C" ), go directly to Step E, SHELVING INSTALLATION.



**STOREMORESTORE**  
Efficient Productive Storage Products

1-855-786-7667

[WWW.STOREMORESTORE.COM](http://WWW.STOREMORESTORE.COM)

## D. MASTER SHELF INSTALLATION

1. Determine the correct height for your Master Shelf (or Master Shelves) from the chart on page 3 (for preconfigured cabinets); or from the customer or specifier (for specially-configured cabinets which have an "X" in the model number). Then, find the correct location on the inside end panel for the Master Shelf will rest when installed.
2. Install one of the load clips (found taped under the bottom of the Master Shelf) on the marked loops. The wide end of the load clip supports the Master Shelf, with the narrow end flush against the inside end panel. The long un-notched end of the load clip goes towards the rear of the cabinet (left and right load clips are different).
3. (See drawing A.) To install, tilt the load clip slightly so that the small tabs in the notches slide up into the matching loops in the inside end panel; then tilt the load clip back so that the narrow side fits flush against the inside end panel, locking the load clip in place. Install the second load clip in the loops on the other inside end panel level with the first load clip.
4. Place the master shelf on top of the load clips and slide it straight back all the way into the cabinet. Check that the openings above and below the Master Shelf are correct; if not, reinstall the master shelf properly.

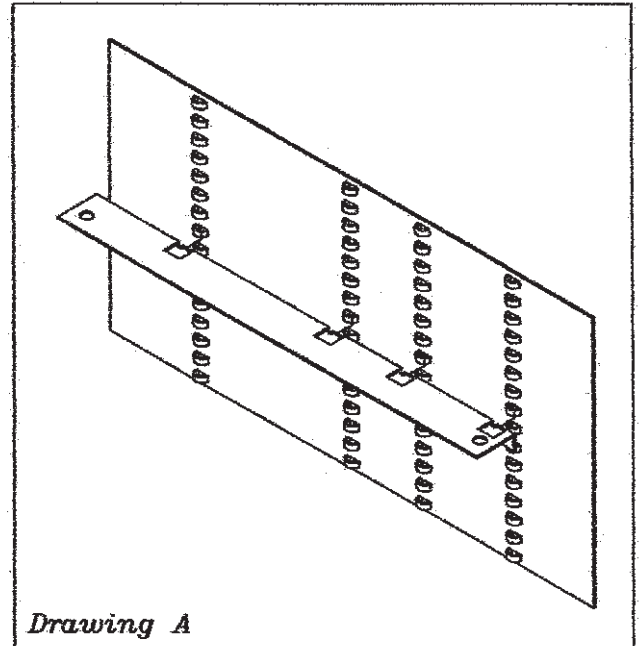

## E. MASTER SHELF INSTALLATION

1. All preconfigured models (no "X" in the model number) use a combination of 10"W, 11"W, and/or 12"W shelves (except for Configuration E, which has no shelves) as follows:
  - 36"W preconfigured cabinets have three columns of shelves; two columns have 11"W shelves, one column has 12"W shelves.
  - 42" W preconfigured cabinets have four columns of shelves, all shelves are 10"W.
2. Remove shelves and shelf supports from cartons. Keep same sized shelves and other like parts together.
3. Determine the location for each shelf support (on a Master Shelf, or on bottom of the cabinet for Configurations "B" or "C") as follows:
  - 36" W preconfigured cabinets: each of the two shelf supports should be installed 11" (or 11 slots) from the left and right sides, leaving 12" (or 12 slots) between the two shelf supports when installed.
  - 42"W preconfigured cabinets: the three shelf supports should be installed to create four equal column widths of 10" (or 10 slots) each.
  - specially-configured cabinets: refer to sketch or drawing provided by customer or specifier.

**Configuration A**

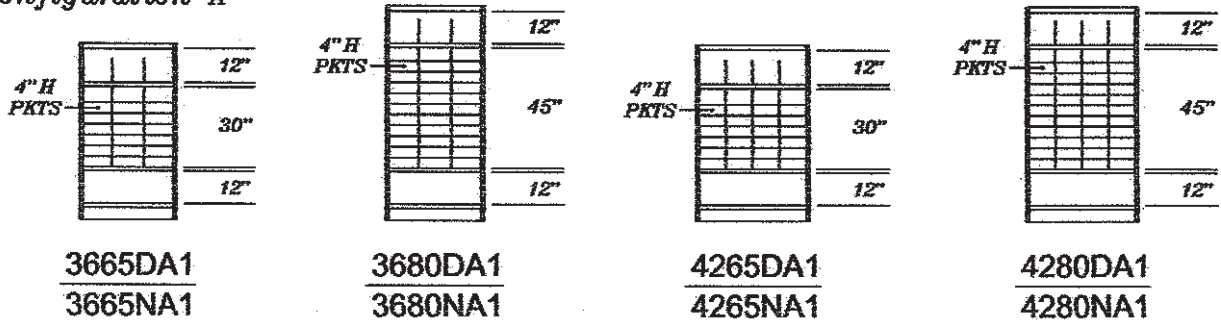

**Configuration B**

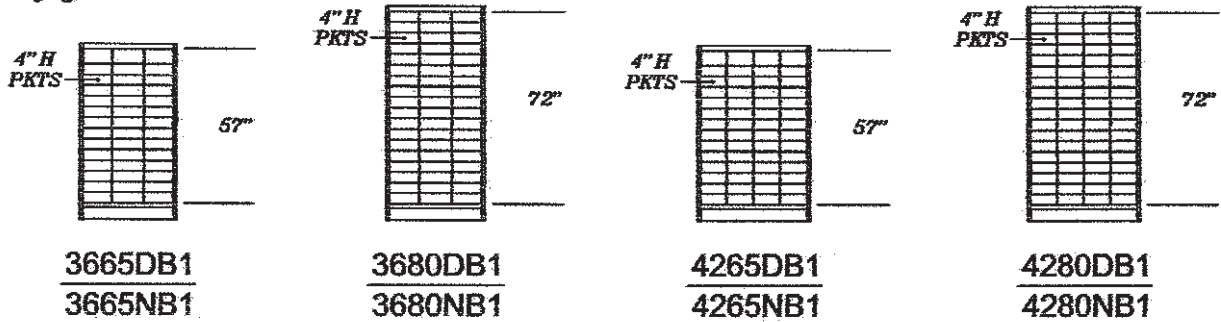

**Configuration C**

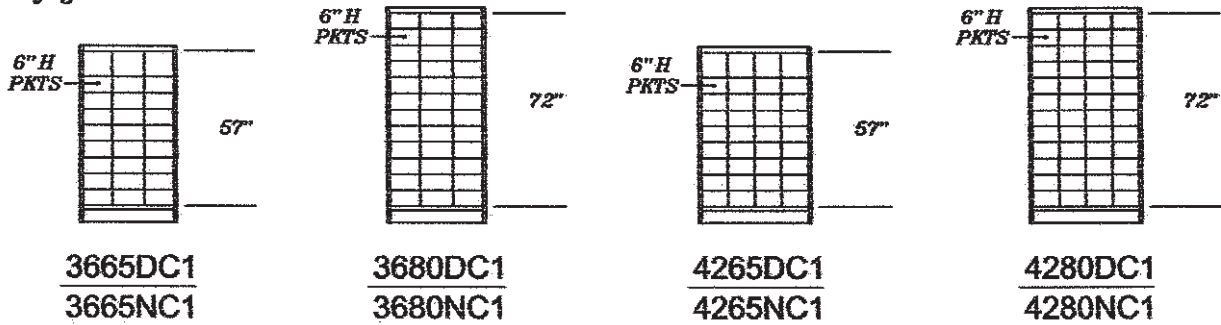

**Configuration D**

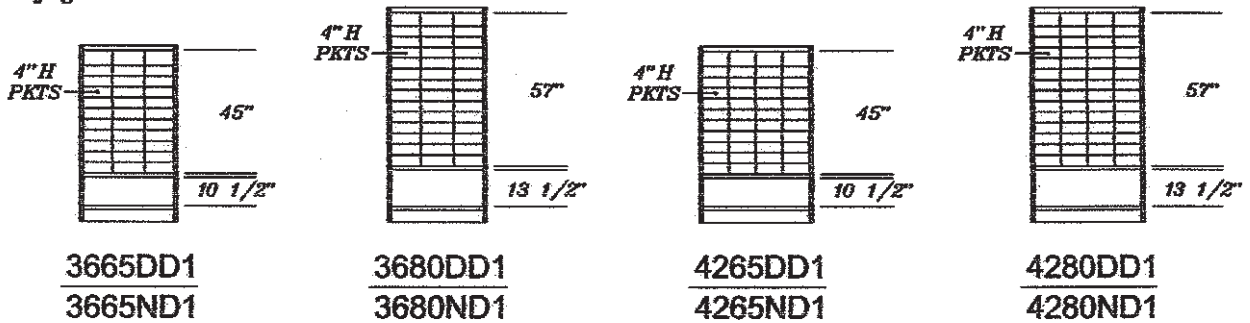

**Configuration E**

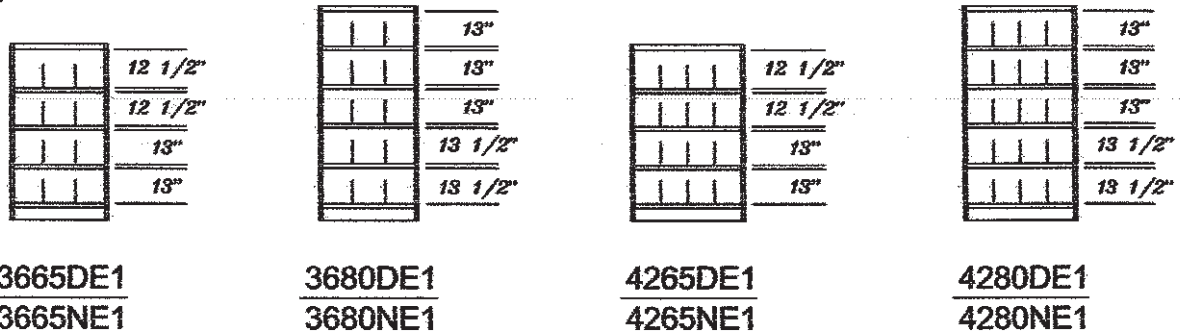

4. Insert the shelf support feet into the proper slots; the top of the shelf support is inserted in the corresponding slot above, under the inside top of the cabinet. (For Configuration "A" or specially-configured cabinets with multiple Master Shelves, the top of shelf supports, except for the top Master Shelf, will not be retained by an overhead slot. However, the shelving system ensures that all shelves lock in place, providing a rigid structure.)

5. Begin installing shelves at either the left or right end columns, starting at the Master Shelf and working up the column until it is filled with shelves. Then move to the next column and continue until all columns are filled with shelves.

6. Configuration A, B, and D cabinets provide 4" H pockets between shelves (Configuration C has 6" H pockets), although shelves can be adjusted on 1/2" vertical increments to create a range of pocket heights.

## F. DOOR INSTALLATION

1. For cabinets with doors (5th digit in model number is a "D"), the doors are packed in a carton separate from the cabinet; the door hardware is packaged inside the cabinet.

2. See *Drawing B* for location of the door hardware and parts, which include:

- 4 door hinges, with 8 Phillips head screws and 4 hinge pins.
- magnetic door catch, with 2 screws.
- 2 keys taped to inside of door
- locking rod (already assembled in door)

3. Holes for door hinges are pre-drilled on the upper and lower left and right front sides of cabinet. Hinges are interchangeable; mount the hinges with the hinge pin holes facing the outside of the cabinet; don't fully tighten the screws until later (see #5 below).

4. Install the small magnetic door catch in the pre-drilled holes on the underside of the front top of the cabinet on the right side, leaving the screws finger-tight.

5. Install the doors using the hinge pins; once the doors are properly installed, fully tighten the hinge screws.

6. Adjust, then tighten the magnetic catch so the door catches smoothly when closed.

