

Parachute Rack™

S T O R A G E S Y S T E M

INFO SHEET

STORAGE SYSTEMS

SAFE AND SECURE PARACHUTE STORAGE by Spacesaver®

When you trust your life to your parachute you can trust Parachute Rack by Spacesaver to store it safely and securely.

The durable and user-friendly Parachute Rack optimally stores your parachutes out of harms way. Combine Parachute Rack with a Spacesaver Eclipse® Powered System and Touchpad with Display and Audit Control and you have the best in asset protection, use of floor space, and security.

FEATURES:

- Made in the U.S.A
- Rugged all steel construction
- Durable powder coat paint – many standard colors available
- Adjustable cantilever arms accommodate different size bags for changing needs
- Infinitely adjustable horizontally
- Adjustable on 6" increments vertically
- Cantilever arms are securely held in place by a thumb screw eliminating the need to use tools
- Organized storage solution provides optimum storage density and efficiency
- All materials used in the fabrication of the Parachute Rack are "non-reactive" preventing degradation of the stored materials
- All corners are rounded and all exposed edges are meticulously deburred to prevent snagging or puncturing of stored materials
- Single and double-faced units available
- Racks can be custom sized to match your application

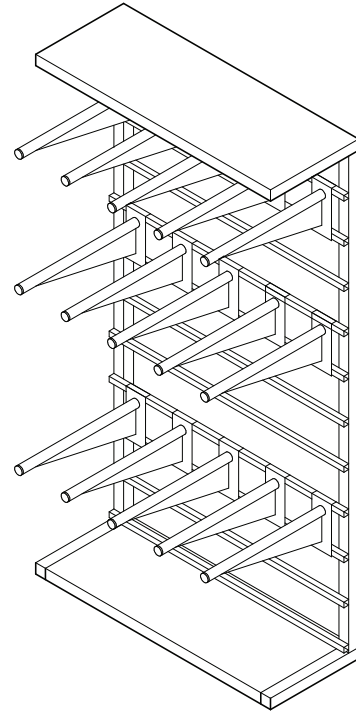

PARACHUTE RACK & ECLIPSE® POWERED SYSTEMS

The ultimate in efficiency and security.

Parachute Rack and Spacesaver Eclipse powered mobile systems are designed to work together. The Parachute Rack sections easily mount to the top of the mobile carriages to work as an integrated storage system. Optimize the use of your valuable floor space by compacting your storage into a smaller footprint.

BEFORE



AFTER

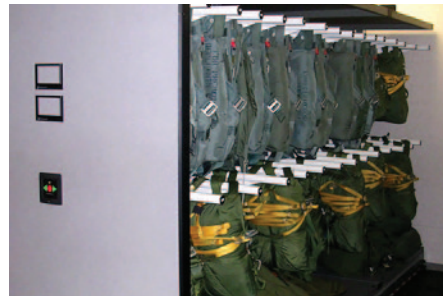

TOUCHPAD CONTROL WITH DISPLAY AND AUDIT TRAIL

Eliminate the need for space-wasting wire cages by securing your Parachute Rack and Eclipse system with the Spacesaver Touchpad with Display and Audit Trail.

BENEFITS:

- Helps protect sensitive materials from access by unauthorized persons.
- Enhances workplace efficiency with its easy-to-read display, available in multiple languages.
- Assists in maintaining personnel accountability by providing a clear record (audit trail) of access with the use of its own easy-to-use PC interface software.
- PIN-code and audit trail memory retention during a power interruption save bothersome reprogramming as well as maintains controlled access when power resumes.
- Adapts easily to your facility's changing security and use requirements with its versatility and multifunctional capability.



● ● ● ● ●

SOUTHWEST SOLUTIONS GROUP
business organization systems
www.southwestsolutions.com