

Storage Solved®

ROTARY STORAGE SYSTEMS



SPACESAVER ROTARY STORAGE SYSTEMS

Design Features

MAXIMUM SPACE EFFICIENCY

Maximizing office floor space is essential, given today's high facilities costs. Spacesaver Rotary Storage Systems are the space-efficient and cost-effective alternative to lateral and vertical files. Rotary Storage offers the same capacity as conventional file cabinets in a fraction of the floor space. And Spacesaver meets virtually every height requirement in the industry. Spacesaver Rotary Storage allows you to do more with less – less space, less time and less labor.



- Rotating Back-To-Back Storage Components Spacesaver Rotary Storage units rotate to provide easy access to back-to-back storage compartments. When not in use, files can be locked in the closed position to present a clean, uncluttered appearance.



- Simple Operation To rotate, simply depress the foot pedal and gently push. Spacesaver Rotary Storage automatically stops in the next position – either fully-opened or fully-closed. When you hold the foot pedal down, the unit rotates freely. To address ADA issues, just lock the foot pedal in the “freespun” position.

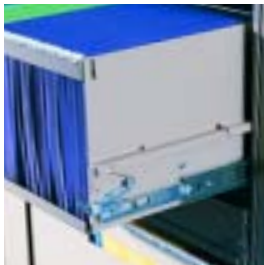

- Sturdy Drawer Guides Drawers roll out on sturdy ball-bearing guides to provide years of smooth, trouble-free operation.



- Roll-Out Reference Shelves Optional roll-out reference shelves serve as handy work surfaces, making storage and retrieval more efficient, while providing a convenient way to review materials on the spot.





MAXIMUM FLEXIBILITY

The greater capacity of Spacesaver Rotary Storage is the result of innovative back-to-back revolving storage compartments. Our Rotary Storage units rotate to give access to two banks of stored materials, increasing flexibility in office design. Choose single-sided access when using them in alcoves or against walls and panels. Choose double-sided access when using them as room dividers. Either approach is effective when you want a space-saving way to share storage between workstations.

- [Security Drawers](#) For restricted access to confidential information or maintaining privacy for multiple users, Security Drawers are the answer. Simply issue keys to authorized personnel.
- [Key Lock Options](#) You decide whether one key unlocks multiple units or just one. The Rotary Storage key number can be coordinated with other Spacesaver storage products – another Spacesaver innovation.
- [Secure Drawer Latches](#) Drawer latches, complete with torsion springs, keep drawers securely closed when not in use – another exclusive Spacesaver design feature.
- [Adjustable Drawers and Shelving](#) Drawers and shelves can be adjusted vertically in increments of 1-3/4" (44 mm), permitting a wide variety of custom configurations. Fixed shelves snap into place without the use of hardware. Drawers and Roll-Out Shelves attach easily in seconds with our matching set screw design. It's just one reason our drawer options are the most versatile in the industry.



SPACESAVER ROTARY STORAGE SYSTEMS

Design Features

WHAT CAN BE STORED IN A SPACESAVER ROTARY STORAGE SYSTEM?

Virtually any type of material, including binders, CD's, videos, supplies and, of course, hanging files. Our rotary units function as efficient multi-media storage systems. A wide variety of items can be stored in the same cabinet. As your needs change, interior drawers and shelving can be easily reconfigured. When more capacity is needed, additional units can also be added.

Spacesaver Rotary Storage is available in 20 standard colors to complement any office interior. To ensure lasting good looks, the durable powder-coated finish is textured to conceal fingerprints and smudges. But the real beauty is in its functionality. Spacesaver's high-capacity Rotary Storage Systems are an innovative way to conserve floor space and lower storage costs.

GREATER STORAGE CAPACITY/LOWER COSTS

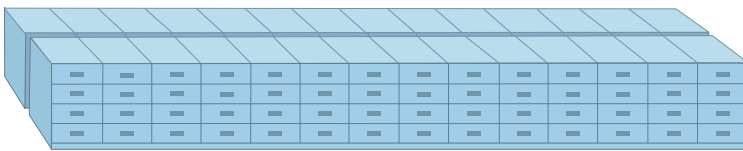

4-DRAWER LATERAL FILES
10.6 Linear File Inches/Sq. Foot
2.9 Linear File Meters/Sq. Meter

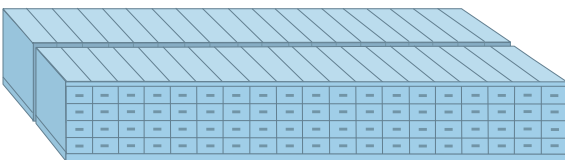

4-DRAWER VERTICAL FILES
14.5 Linear File Inches/Sq. Foot
4.0 Linear File Meters/Sq. Meter

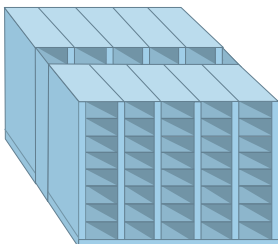

SPACESAVER 8-TIER ROTARY STORAGE

27.4 Linear File Inches/Sq. Foot
7.5 Linear File Meters/Sq. Meter

These 10 Rotary Storage units hold the same amount of materials as 28 4-drawer lateral or 38 4-drawer vertical files.

Each of the systems shown above provide the same storage capacity, but Spacesaver Rotary Storage units consume less than half the floor space. The net result – Spacesaver Rotary Storage Systems are a better, more space-efficient way to lower your storage costs.



MIX AND MATCH ROTARY UNITS TO MEET YOUR INDIVIDUAL REQUIREMENTS

Shown below are five Spacesaver 7-tier Rotary Storage units, configured as 1 Starter Unit with 4 Adder Units.

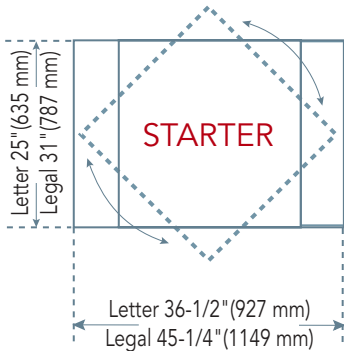
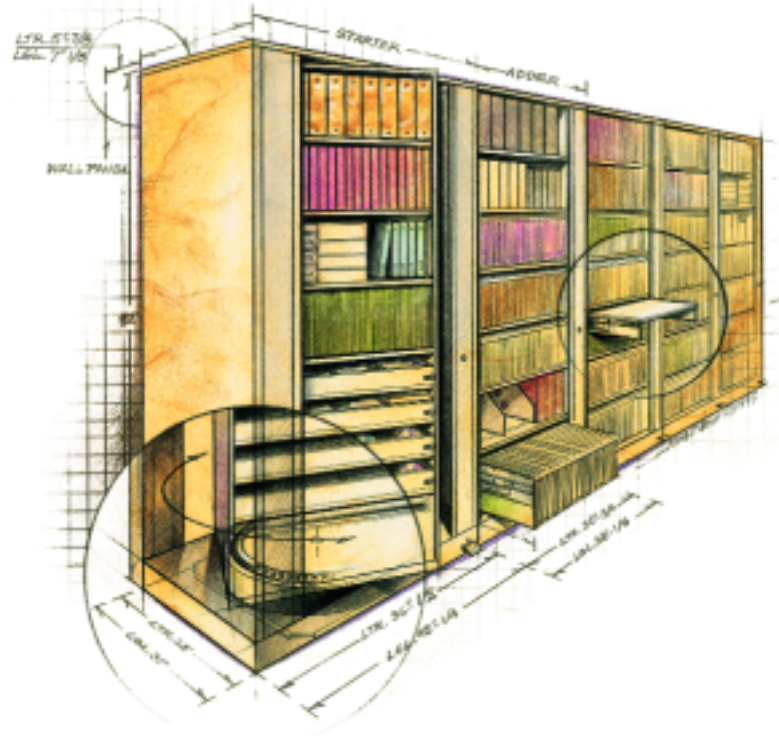

STARTER

The first cabinet in any row of Spacesaver Rotary Storage units is always a Starter. This unit can stand alone, or Adder units can be connected to either side.

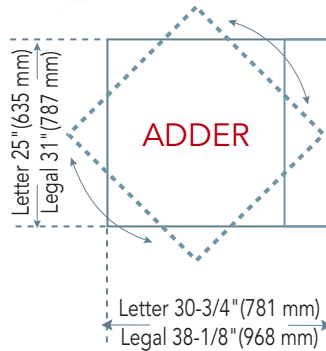

ADDER

Sharing rotation space with their neighbors, Adder units reduce the necessary floor space of a Starter by 6 inches in width. The number of Rotary Storage units that can be connected together is limited only by the physical constraints of your space plan.

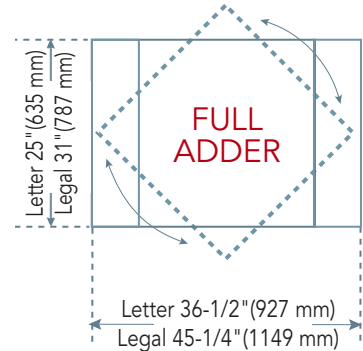

FULL ADDER

Where active files demand increased accessibility, a Full Adder allows the freedom of simultaneous access to adjoining units. Connected to a Starter, the Full Adder does not share rotation space with its neighbor.

DIMENSIONAL SPECIFICATIONS

The heights, widths, depths and capacities of Spacesaver Rotary Storage units are shown below. Consult your local Area Contractor for recommended configurations.

STARTERS AND ADDERS

STARTERS AND FULL ADDERS

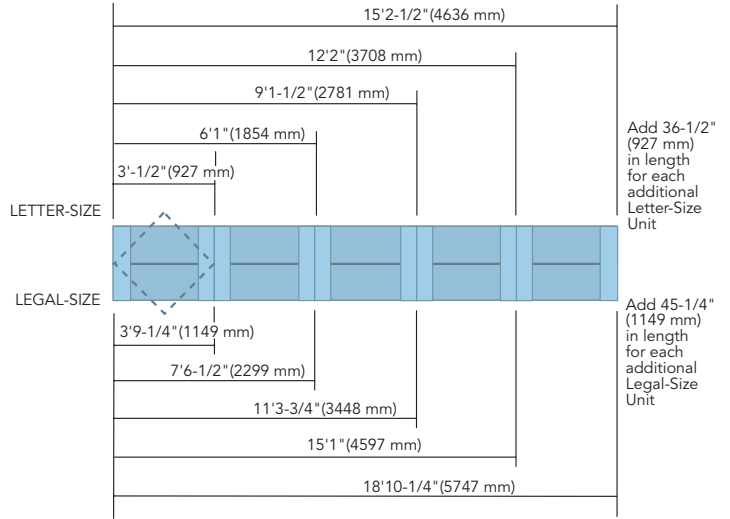
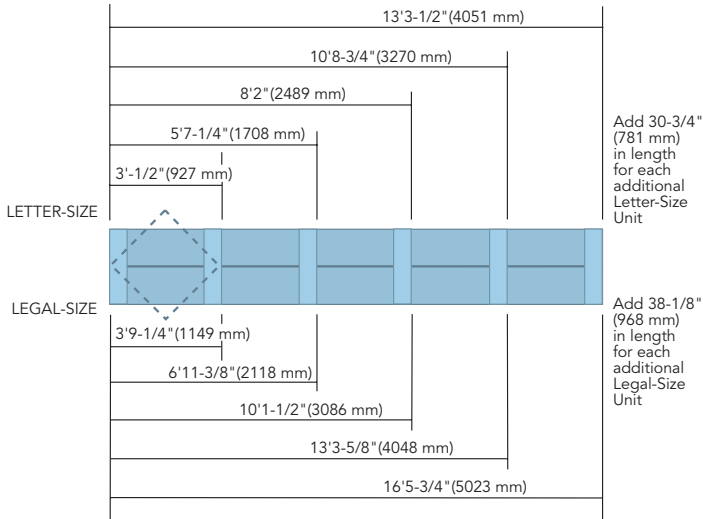

UNIT HEIGHTS

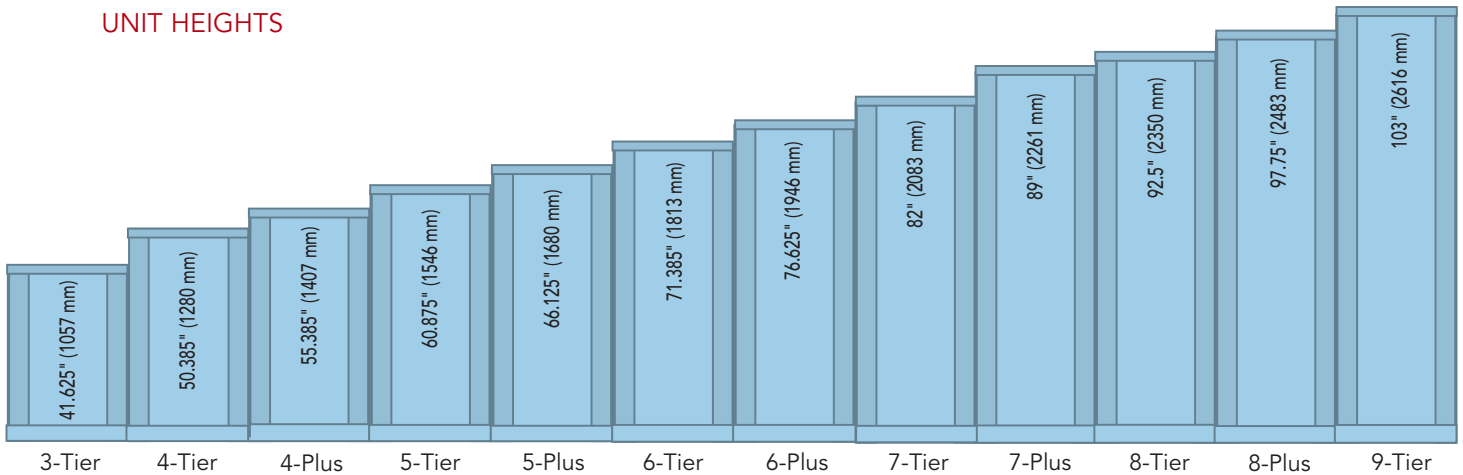

CAPACITY	CAPACITY	CAPACITY	CAPACITY	CAPACITY	CAPACITY	CAPACITY	CAPACITY	CAPACITY	CAPACITY	CAPACITY	CAPACITY
Letter: 144 linear file inches (3658 mm)	Letter: 192 linear file inches (4877 mm)	Letter: 192 linear file inches (4877 mm)	Letter: 240 linear file inches (6096 mm)	Letter: 240 linear file inches (6096 mm)	Letter: 288 linear file inches (7315 mm)	Letter: 288 linear file inches (7315 mm)	Letter: 336 linear file inches (8534 mm)	Letter: 336 linear file inches (8534 mm)	Letter: 384 linear file inches (9754 mm)	Letter: 384 linear file inches (9754 mm)	Letter: 432 linear file inches (10973 mm)
Legal: 180 linear file inches (4572 mm)	Legal: 240 linear file inches (6096 mm)	Legal: 240 linear file inches (6096 mm)	Legal: 300 linear file inches (7620 mm)	Legal: 300 linear file inches (7620 mm)	Legal: 360 linear file inches (9144 mm)	Legal: 360 linear file inches (9144 mm)	Legal: 420 linear file inches (10668 mm)	Legal: 420 linear file inches (10668 mm)	Legal: 480 linear file inches (12192 mm)	Legal: 480 linear file inches (12192 mm)	Legal: 540 linear file inches (13716 mm)

SPACESAVER ROTARY STORAGE SYSTEMS

S t o r a g e S o l v e d ®

ASK US FOR A PROFESSIONAL ASSESSMENT OF YOUR STORAGE NEEDS

Rely on The Spacesaver Group – the high density storage experts. As our ISO 9001 certification would suggest, Spacesaver is dedicated to the highest standards of product quality. Equally important is our commitment to customer service. Our team of experienced Area Contractors are problem solvers who can make an invaluable contribution to your planning process. For a qualified professional assessment of your storage needs, give us a call at 1-800-492-3434. There is no cost or obligation.



USA

1450 Janesville Avenue
Fort Atkinson, Wisconsin
53538-2798 USA
Telephone 920/563-6362
Toll Free 800/492-3434
Fax 920/563-2702

Canada

266 King Street East
Toronto, Ontario M5A 4L5
Telephone 416/360-1022
Toll Free 800/544-3679
Fax 416/360-7290

United Kingdom

Commonwealth House
148-153 High Holborn
London, England WC1V 6PJ
Telephone 020/7404-7441
Fax 020/7404-7442



Spacesaver®

S t o r a g e S o l v e d ®

website: www.spacesaver.com
email: ssc@spacesaver.com

