

High-Density Mobile Storage

ACHIEVING ADA
COMPLIANCE WITH
MOBILE STORAGE

Storage Solved®



Spacesaver®

Accessibility has always been Mobile's goal	3
Space-saving compliance	3
ADA Considerations in Mobile	6
Other sources for ADA information	10
Canada's barrier-free design	11

By Jim Muth
Vice President of Operations
Spacesaver Corporation

ACCESSIBILITY HAS ALWAYS BEEN MOBILE'S GOAL

High-density mobile storage systems can provide people with physical disabilities access to materials and files in a way that complies with not only the letter, but also with the spirit of the Americans with Disabilities Act (ADA). What's more, it can do it in less space than conventional storage systems.

Storage — although not as high a priority as entrances and toilets — is addressed in the Title III Nondiscrimination on The Basis of Disability By Public Accommodations and in Commercial Facilities section of the ADA. It will no doubt become more important as the enforcement of ADA evolves.

An obvious short-term solution to inaccessible storage is for stored items to be retrieved by someone else for people who cannot access the storage area themselves. However, this may not be practical, and is time intensive and costly over the long run. Employers and building and facility professionals should plan for future compliance as well as meeting immediate needs.

More important than the letter of the law is the fact that convenient, accessible storage areas help create an environment in which people with disabilities (as well as those without) can contribute to their full potential. Making facilities accessible benefits not only people who are permanently disabled, but also those who are temporarily disabled because of accident or illness, getting them back to productive work.



International Accessibility symbols

SPACESAVING COMPLIANCE

Mobile storage systems feature storage units mounted on wheeled carriages that run on tracks in the floor. Rather than having to allow for an access-width aisle between each storage unit, mobile systems create the aisle wherever the operator wants access.

The carriages are compacted to create the accessible aisle by one of three methods: manually, mechanical assist or using powered push-button controls. By far the easiest to operate and, therefore, the most accessible systems are powered. In addition, powered systems offer programming flexibility and additional safety features which will be described later in this report.

By compacting the storage units, the space savings for a building owner/professional is significant. Switching from stationary storage to high-density mobile storage reduces the amount of floor space required by 50 percent or more (See Fig. 1 on next page). This allows more storage to be located in smaller areas and/or near the workstations where they are needed, thus reducing the amount of travel required for access.

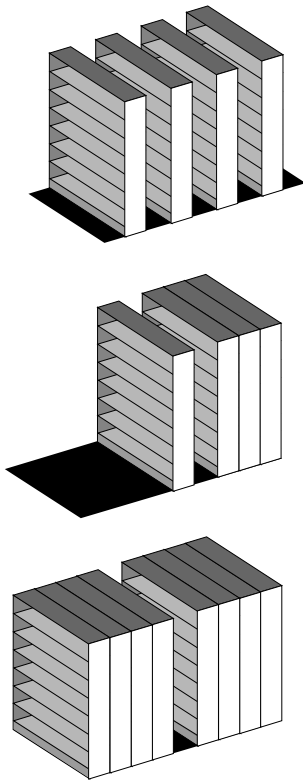

Figure 1. (Above) Eliminating conventional fixed aisles (top) and compacting the storage to allow for a compliant movable aisle saves 50 percent of the floor space (center) or provides 100 percent more storage capacity in the same amount of space (bottom).

Figure 2. (Right) Mobile storage makes more efficient use of office space — increasing storage capacity by as much as 300 percent — compared to other storage equipment. As this chart illustrates, an average-sized office requiring about 1,200 filing inches (30.5 m) of storage can be served by a mobile system in one-third of the floor space required by other types of equipment.

The space-savings can also free up space for additional workstations. People with disabilities should work alongside people without disabilities, rather than being relegated to “special” areas where they may be isolated. Filing capacity can increase as much as 300 percent over conventional file cabinet storage by claiming overhead air space as well as aisles (consider reach limits when accessing for people with disabilities). In fact, mobile storage offers more filing inches per square foot than other storage equipment (Fig. 2). This space efficiency translates into convenience, time savings in storage and retrieval, and less cost in space (construction, rent, utilities).

FILING SYSTEM SPACE REQUIREMENT COMPARED:

Spacesaver Mobile System

3 units occupy 24.9 square feet producing 1,360 lineal inches.

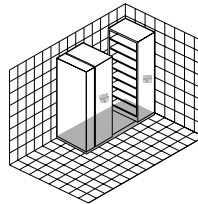

54.6 filing/storage inches per square foot

Lateral Sliding Shelves

5 (8-tier) units occupy 34.9 square feet producing 1,360 lineal inches.

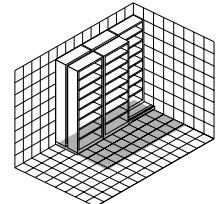

39.0 filing/storage inches per square foot

Open Shelf

5 sections occupy 37.5 square feet producing 1,360 lineal inches.

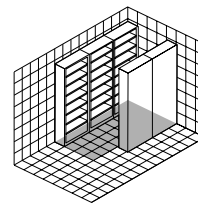

36.3 filing/storage inches per square foot

Rotary Shelving

4 (8-tier) units occupy 45.7 square feet producing 1,344 lineal inches.

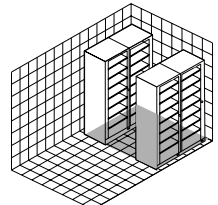

29.4 filing/storage inches per square foot

4-Drawer Vertical Files

5 sections occupy 55.6 square feet producing 1,152 lineal inches.

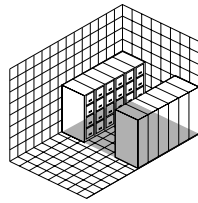

20.7 filing/storage inches per square foot

Mechanical Vertical

1 unit occupies 67.8 square feet producing 1,232 lineal inches.

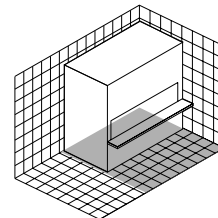

18.2 filing/storage inches per square foot

4-Drawer Lateral Files

8 cabinets occupy 86.3 square feet producing 1,440 lineal inches.

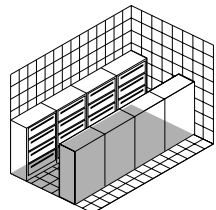

16.7 filing/storage inches per square foot



Figure 3. Colored end-tab files on a mobile system are easily accessed by anyone.

Items stored in mobile storage are easily seen and/or felt and quickly retrieved. There is no need to rifle through file drawers, storage closets or boxes. Adding colored end-tab file folders makes filing especially efficient (Fig. 3.)

Some mobile systems offer automatic aisle lighting, which turns lights on over an aisle as it is chosen for access and shuts them off automatically as the aisle closes, thus eliminating the need to hunt for and access light switches (Fig. 4.)



Figure 4. Automatic aisle lighting eliminates the need to hunt for and access light switches.

Safety devices will stop moving carriages in case of emergency. Sweeps, infrared sensors and stop buttons are easy to operate and can be located within easy access of everyone. Systems equipped with a Zero Force Sensor® or AisleGuard® Safety System prevent carriage movement when someone is in an aisle and stop carriage movement when a person enters an aisle (Fig. 5.)

Mobile's flexibility means systems can be designed to store and protect almost anything: files, X-rays and other medical records, general and office supplies, legal records and reference books, component parts, electronic data cartridges and tapes. What's more, systems can be moved, reconfigured or expanded as storage needs, or the needs of people, change.

Mobile storage is not specifically addressed in the ADA, however, several guidelines can be applied to making the systems accessible to people with disabilities.



Figure 5. Devices such as a passive safety and/or safety sweep prevent or stop carriage movement when someone is in an open aisle.

ADA CONSIDERATIONS IN MOBILE

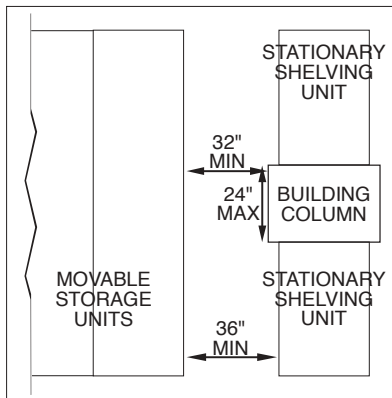

Figure 6. According to the ADA, aisles must be a minimum of 32 inches (815 mm) at a point and 36 inches (915 mm) for continuous clearance for a wheelchair.

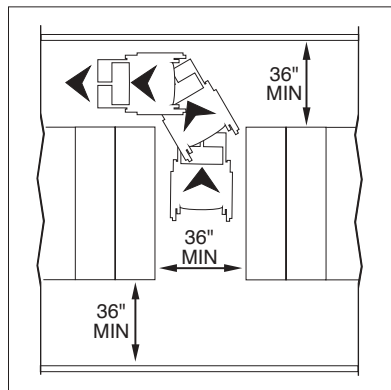

Figure 7. Dual access aisles may eliminate the need for a turnaround space if all areas are a compliant width of 36 inches (915 mm).

The ADA recognizes and protects the civil rights of people with disabilities. Revised ADA accessibility guidelines were proposed April 2, 2002¹ and should be finalized by 2003. These guidelines cover new construction as well as alterations to existing facilities, and apply to places of public accommodation, commercial facilities, and state and local government facilities.²

The following ADA accessibility guidelines for building and facilities apply to mobile storage.³ The ADA sets **minimum** standards. State and municipal laws vary and are subject to interpretation on a case-by-case basis; therefore, it is important to be familiar with local accessibility requirements and trends. Consult local codes prior to finalizing your space plan.

Aisles must be 32 inches (815 mm) minimum at a point (maximum length 24 inches (610 mm) and 36 inches (915 mm) continuous clearance for a wheelchair (Fig. 6); 42 inches (1067 mm) is preferred for libraries. Mobile can provide the wide aisle in much less overall space than stationary shelving, which has to provide the space between each unit.

Wheelchair turning — If wheelchair turning (180 degrees) is needed, a clear floor space of 60 inches (1525 mm) or a T-shaped space consisting of 36-inch (915 mm) wide aisles is required. The ADA sets a maximum aisle length of 200 feet (60.98 m) before a turnaround or passing space is required; once again, this must be determined on an individual basis, depending on the physical limitations of both the facility and the person using the storage system.

There are several considerations and options:

- Length of the aisle — Some systems may be short enough that a person using a wheelchair can back out of a single-entry aisle with relative ease.
- Dual access aisles — Providing access on either end of an aisle may eliminate the need for a turnaround. People using wheelchairs can simply enter one end of the aisle and exit the other end (Fig. 7). Care must be taken that access aisles outside the system (such as those between a system and a wall) are also a compliant width.

¹From the Federal Register Vol. 67, No. 63: Americans with Disabilities Act (ADA) Accessibility Guidelines for Buildings and Facilities; Architectural Barriers Act (ABA) Accessibility Guidelines. For further information, contact the Office of Technical and Information Services, Architectural and Transportation Barriers Compliance Board.

²The proposed rules revise and update the accessibility guidelines for buildings and facilities covered by the American with Disabilities Act of 1990 (ADA) and the Architectural Barriers Act of 1968 (ABA). Revised guidelines for both ADA and ABA are consolidated in one Code of Federal Regulations part. The ABA covers facilities designed, built, altered, or leased with Federal funds. The revised guidelines also are being developed in conjunction with future ANSI standards with the cooperation of the ICC (International Code Council) to reduce conflicts between the guidelines and the standards.

³Where the IBC (International Building Code) has been adopted, ANSI A117.1 may be the standard for local plan review and code enforcement. As the ADA guidelines have been based upon these ANSI standards, the two are very similar.

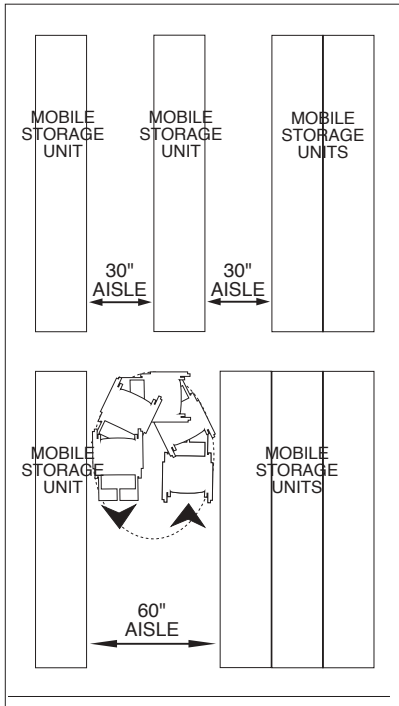

Figure 8. A mobile carriage can be positioned to create two 30-inch (762 mm) aisles or moved to create a 60-inch (1525 mm) aisle to accommodate wheelchair turnaround.

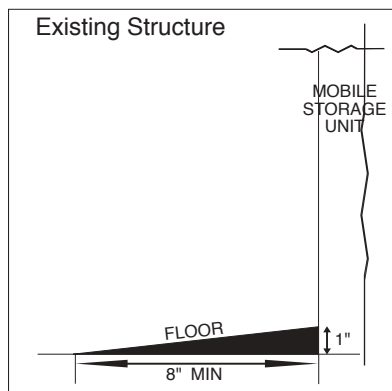

Figure 9. Low-profile mobile systems — extending above the floor one inch (25 mm) — in existing structures, must be equipped with a ramp of at least 8 inches (203 mm) to be accessed by a person with a disability.

- Turnaround aisles — In a mobile system, allowing for a 60-inch (1525 mm) aisle for wheelchair turnaround can also create two 30-inch (762 mm) aisles for people not using wheelchairs (Fig. 8). In manual or mechanical systems set up for a 60-inch (1525 mm) aisle width, two narrow aisles can be created by simply moving a carriage to create an aisle on either side.

A powered system equipped with a programmable aisle feature can be set to lock a carriage, making it a stationary platform with an aisle on either side. When a wheelchair turnaround aisle is needed, the carriage is unlocked so that one 60-inch (1525 mm) aisle is created. In a Spacesaver system the change is made using an access key.

Floor surfaces, including ramps and aisle floor surfaces, must be stable, firm and slip-resistant. Rails should be flush with the system floor surface to assure that there are no hazards to those walking or operating wheelchairs in the aisles.

Ramps are required where there is a change in levels greater than 1/2 inch (12.7 mm). Because of the rails, most mobile systems will require ramps to access the system using a wheelchair.

Ramps installed in existing structures must have a slope not steeper than 1:10 with maximum rise of six inches (152 mm) or a slope not steeper than 1:8 with maximum rise of three inches (76 mm). In new construction, the maximum slope permitted is 1:12.

The mobile system contractor will calculate ramp requirements for the specific application. For example, Spacesaver's low-profile mobile system extends about one inch (25 mm) above the surrounding floor, thus requiring a ramp of 8-12 inches (203-305 mm) in length (Fig. 9); systems using T-rails can be up to 2-1/2 inches (63.5 mm) above the floor, requiring ramps of 20-30 inches (508-762 mm). Whether installing a mobile system constitutes new construction depends on the authority having jurisdiction.

Opening force for doors cannot exceed 5 ft-lb, (0.6912 kgm) according to the ADA. This can be translated to manual and mechanical-assist movable storage units; however, it is not the only criteria to use in determining what method of control to choose.

The primary concern is how easily a person using a wheelchair can operate the system. Manual systems, which a person opens by pushing or pulling, are not recommended except for very light loads on short carriages. It requires one pound of force to start moving about 2,000 pounds of stored media on a manual unit. For example, a unit storing X-rays five levels high weighs about 1,000 pounds per linear foot (1500 kg/m); its maximum length to stay within the 5 ft-lb (0.6912 kgm) guideline is 10 feet (3050 mm).

Unless the wheelchair is locked in place, pushing the carriage will exert an equal reverse force that pushes the chair away from the system. For smooth operation, a person using a wheelchair may have to travel along with the carriage as it moves.

Traveling with the moving carriage is also likely with a mechanical system. Some manufacturers offer optional gear ratios on mechanical-assist controls that may help meet the 5 ft-lb force guideline. Assuming each mobile unit is moved one at a time, a 21-foot-long unit (6.4 m) with 1,000 pounds per linear foot (1500 kg/m) of media and equipment weight will require a gear ratio of 5,000/1 to provide an opening force of 4.2 ft-lb.

Electric motorized automatic systems are the best solution, since the carriages are easily moved by someone using a wheelchair, with just the touch of a button. A remote control device offers added convenience. The movement is smooth and controlled and the person doesn't have the inconvenience of having to travel with the carriage and then return to the open aisle.



Figure 10. Control guidelines for elevators can be applied to mobile storage. The controls must fall within a height range of 35-48 inches (889 mm-1220 mm) from the floor.

Control height in ANSI A117.1 sets a range from the floor of 35-48 inches (889-1220 mm) for elevator call buttons. The same range can be applied to mobile storage system controls.

If a person using a wheelchair must access forward to operate the mobile system, make sure that the controls fall in the required range, even with the additional rail height. For example, the buttons controlling movement in Spacesaver electric systems are at a height of 44 inches (1118 mm) (Fig. 10); the mechanical control is within the access guideline at the center of its hub, but the top spoke may require assistance.

Type of controls recommended are touch or U-shaped pulls for doors; these guidelines should also be followed for mobile systems that will be operated by people with disabilities. As discussed earlier, manual systems — for which a U-shaped pull will be necessary — are not recommended for most accessible situations.

Powered controls are the easiest to operate and ensure accessibility to people with almost any type of physical disability. The control buttons should be at least 3/4-inch in (19.06 mm) diameter (Fig. 10). Instructions for operation should be posted next to the controls.

Signage on mobile systems designed for access to people with disabilities should include instructions for operating the systems and a list of carriage contents (Fig. 10). In addition, everyone who will be using the mobile system should receive an orientation on its use and safety features. We recommend positioning the signage adjacent to the controls for easiest access.

The ADA says mounting height for permanent identification (such as contents) is 60 inches (1525 mm) above the floor to the centerline of the sign. A person should be able to approach within three inches of the sign. The decision about character proportion, height and background should be based on the intended viewing distance. Letters and numbers on signs should have a width-to-height ratio between 55 percent minimum to 110 percent maximum of the width; and a stroke-width-to-height ratio between 10 percent minimum and 15 percent maximum of the character, based on the uppercase letter I.

According to the ADA, people with low vision find signs more legible when characters contrast with their background by at least 70 percent; light-colored characters on a dark background usually offer the greatest readability. The characters and background should be in an eggshell, matte or other non-glare finish.

The use of raised or Braille characters and pictorial symbol signs is, once again, dependent on the individual situation, e.g. for mobile systems storing Braille books. Characters should be 5/8"- 2" (15.88 mm- 50.8 mm) in height. Whatever labeling is chosen, use it consistently in the stacks as well.

Although shelf height in stacks is unrestricted, **accessing height and reach limits** for a person using a wheelchair must be considered in loading mobile systems.

Most aisles will be less than 48 inches (1220 mm) wide — the minimum width of floor space which the ADA says is required for forward access from a wheelchair — so will require a parallel approach and side loading and retrieval. ANSI A117.1 sets a side access low of 15 inches (380 mm) and a high of 48 inches (1220 mm) (Fig. 11).

Where an access width of 48 inches (1220 mm) or greater allows a person using a wheelchair to access forward, the maximum forward access is 48 inches (1220 mm) high; minimum low forward access is 15 inches (380 mm).

Forward and side access over an obstacle (such as a shelf) must be equal to or less than the floor clearance of wheel chair.

It's best to adjust per the individual's comfort level and ability, and may be further determined by the type of material being stored (files versus boxes). This doesn't mean that items can't be stored above or below the ANSI A117.1 ranges, as long as provisions are made for the person (e.g. another employee retrieves out-of-access items) or duplicate items are stored at an accessible level.

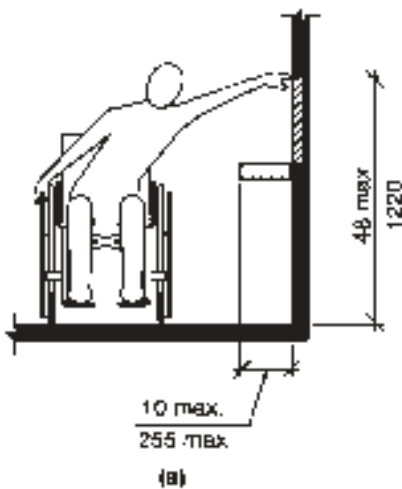

Figure 11. **Unobstructed High Side Reach.** Where a clear floor or ground space allows a parallel approach to an element and the side reach is unobstructed, the high side reach shall be 48 inches (1220 mm) maximum and the low side reach shall be 15 inches (380) minimum above the floor or ground.

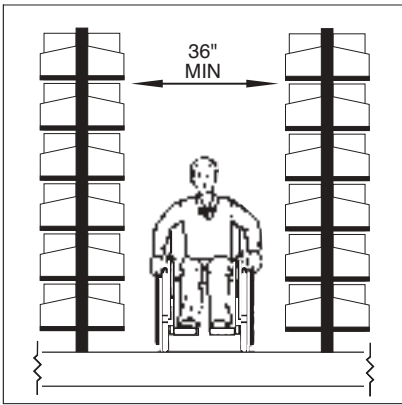

Figure 12. Library stacks must have a clear aisle width of 32 inches (815 mm) at a point and 36 inches (915 mm) continuous clearance; 42 inches (1067 mm) is preferred.

Library stacks and magazine displays are specifically addressed in the ADA. As with other aisles, the minimum clear aisle width between stacks is 32 inches (815 mm) at a point and 36 inches (915 mm) continuous clearance for a wheelchair (Fig. 12); however, 42 inches (1067 mm) is preferred for libraries. Shelf height is unrestricted.

For cantilever shelving, consider the **actual** or installed, rather than **nominal** depth of the shelving. For example, Spacesaver's 24-inch (610 mm) shelving is actually 24 inches (610 mm) deep when installed. Depending on the manufacturer, the actual depth may vary by as much as 1/2 inch (12.7 mm), which could make an aisle one inch narrower than planned.

Magazine displays, which some mobile systems offer, are limited to a height 18-54 inches (458 mm-1370 mm), with 48 inches (1220 mm) required by ADA.

The ADA, although mandating some compliance measures, is broadly written and subject to interpretation. It will evolve as people with disabilities continue to assimilate into the workforce and gain more access to public facilities.

The best compliance is flexibility in adjusting to individual needs. Look for creative options to "the way it's always been done," focusing on the objectives and tasks of the work. Ask for feedback from people with disabilities.

Incorporating mobile storage into a building plan is just one way to help assure accessibility now and in the future, for everyone.

OTHER SOURCES FOR ADA INFORMATION

For more information about requirements for accessible design in new construction and alterations contact your local mobile system contractor, architect, designer and the following other sources:

The Access Board

1111 18th St. NW
Suite 501
Washington DC 20036
1-800-USA-ABLE or 202-272-0080 TTY 1-800-933-2822
<http://www.access-board.gov>

Contact the compliance board for information and advice on individual projects.

American National Standards Institute

202-293-8020
<http://www.ansi.org>

Disability & Business Technical Assistance Centers

1-800-949-4232

<http://www.adata.org/dbtac.html>

Technical assistance and some direction to local resources can be obtained from your Disability and Business Technical Assistance Center. The 800 number will automatically ring in the center (there are 10 regional centers in the U.S.) nearest you.

Internal Revenue Service

Washington DC

202-622-3110

<http://www.IRS.gov>

Call the IRS for the most up-to-date information on tax credits for ADA compliance.

International Code Council

703-931-4533

<http://www.iccsafe.org>

Job Accommodation Network

1-800-526-7234

<http://www.jan.wvu.edu>

The Job Accommodation Network (JAN) is a free consultant service that helps employers make individualized accommodations.

Other sources include the U.S. Equal Employment Opportunity Commission, state or local vocational rehabilitation agencies, or state or local organizations representing or providing services to individuals with disabilities.

CANADA'S BARRIER FREE DESIGN

In Canada, the National Building Code includes a section on barrier-free access that is similar to the ADA. In addition, some provinces, such as Ontario, have their own guidelines. For more information, contact:

Canadian Standards Association

178 Rexdale Blvd, Toronto Ontario M9W 1R3, CANADA

416-747-4044

<http://www.csa-international.org>

For a copy of the national standard "Barrier-Free Design" CAN/CSA - B651-95 (R2001).

**National Research Council Canada
Institute for Research in Construction**

Montreal Road, Ottawa Ontario K1A 0R6, CANADA

613-993-2463

<http://www.nrc-cnrc.gc.ca>

The Institute helps callers determine which of its publications are most appropriate.

THE BOTTOM-LINE QUESTION

W h y S p a c e s a v e r ?

As our ISO 9001 certification would suggest, Spacesaver is dedicated to the highest standards of product quality. Equally important is our commitment to customer service, both before the sale and after.

Through our extensive network of local Area Contractors, Spacesaver provides a level of experience and competency that others simply do not. From architectural constraints and building codes to system design and floor-loading, we have the expertise to handle every issue and customer concern.

A storage solution that meets your unique criteria. Single-source turn-key project management. Certified system installation. Ongoing maintenance and support. Spacesaver sets a standard of professionalism, performance and responsiveness that is unmatched. We live up to our customer commitments and have the references to prove it.

You can rely on The Spacesaver Group.

USA

1450 Janesville Avenue
Fort Atkinson, Wisconsin
53538-2798 USA
Telephone 920/563-6362
Toll Free 800/492-3434
Fax 920/563-2702

Canada

266 King Street East
Toronto, Ontario M5A 4L5
Telephone 416/360-1022
Toll Free 800/544-3679
Fax 416/360-7290

Europe

Commonwealth House
148-153 High Holborn
London WC1V 6PJ, UK
Telephone +44 (0)20 7404-7441
Fax +44 (0)20 7404-7442
Email sales@kiuk.co.uk



website: www.spacesaver.com
email: ssc@spacesaver.com

Spacesaver Corporation is a division of KI.



© 2004 Spacesaver Corporation
All rights reserved.
REV. 1.0/SC-0235 SSC/PRI 5/04

KI and Spacesaver are
registered trademarks of
Krueger International, Inc.

